

TM 11-6625-438-15

DEPARTMENT OF THE ARMY TECHNICAL MANUAL

ORGANIZATIONAL, DS, GS, AND DEPOT
MAINTENANCE MANUAL

VOLTMETER, ELECTRONIC AN/USM-98



HEADQUARTERS, DEPARTMENT OF THE ARMY,

JULY 1967

WARNING

DANGEROUS VOLTAGES EXIST IN THIS EQUIPMENT!

Be careful when working on the 115-volt ac line connections. Serious injury or death may result from contact with these terminals.

DO NOT TAKE CHANCES!

**EXTREMELY DANGEROUS VOLTAGES EXIST IN THE
+500-VOLT REFERENCE VOLTAGE POWER SUPPLY**

Before working on this power supply, always short circuit the high-voltage filter capacitors after the power has been removed.

Change }
No. 1 }

HEADQUARTERS
DEPARTMENT OF THE ARMY
Washington, D. C., 21 February 1974

Organizational, Direct Support, General Support,
and Depot Maintenance Manual

VOLTMETER, ELECTRONIC AN/USM-98

TM 11-6625-438-15, 7 July 1967, is changed as follows:

1. A vertical bar appears opposite changed material.
2. Remove and insert pages as indicated in page list below:

<i>Remove</i>	<i>Insert</i>
iii and 1-0	iii and 1-0
1-1 and 1-2	1-1 and 1-2
B-1 through B-3	

3. File this change sheet in the front of the publication for reference purposes.

By Order of the Secretary of the Army:

Official:

VERNE L. BOWERS
Major General, United States Army
The Adjutant General

CREIGHTON W. ABRAMS
General, United States Army
Chief of Staff

Distribution:

Active Army:

USASA (2)
CNGB (1)
ACSC-E (2)
Dir of Trans (1)
COE (1)
TSG (1)
USAARENBD (1)
USAMB (10)
AMC (1)
TRADOC (2)
ARADCOM (2)
ARADCOM Rgn (2)
OS Maj Comd (4)
LOGCOMDS (3)
MICOM (2)
TECOM (2)
USACC (4)
MDW (1)
Armies (2)
Corps (2)
HISA (ECOM) (18)
Svc Colleges (1)
USASESS (5)
USAADS (2)
USAFAS (2)
USAARMS (2)
USAIS (2)
USAES (2)
USAINTS (3)
WRAMC (1)
USACDCEC (10)
ATS (1)
APG (2)
Instl (2) except
 Ft Gordon (10)
 Ft Huachuca (10)
 WSMR (1)
 Ft Carson (5)
 Ft Richardson (ECOM Ofc) (2)
Army Dep (2) except
 LBAD (14)

SAAD (30)
TOAD (14)
ATAD (10)
GENDEP (2)
Sig Sec GENDEP (2)
Sig Dep (2)
Sig FLDMS (1)
USAERDAA (1)
USAERDAW (1)
MAAG (1)
USARMIS (1)
Units org under fol TOE:
 (1 cy each)
 6-100
 6-155
 6-156
 6-185
 6-200
 6-216
 6-300
 7
 7-100
 11-97
 11-98
 11-117
 11-127
 11-158
 11-302
 11-500(AA-AC)
 17
 17-100
 37
 37-100
 44-235
 44-236
 44-536
 44-568
 57
 57-100

NC: State AG (2)

USAR: None

For explanation of abbreviations used, see AR 310-50.

WARNING
RADIATION HAZARD
Co 60

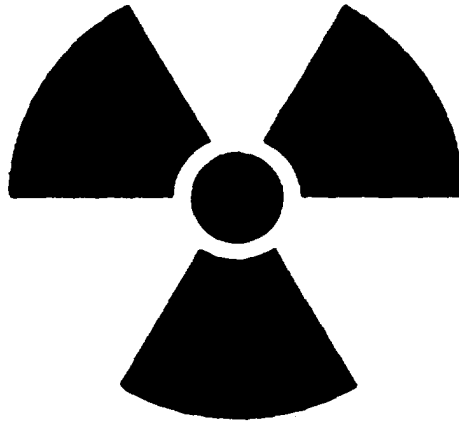

STD-RW-2

Tube types 0A2 and 0B2 used in this equipment contain radioactive material. These tubes are potentially hazardous when broken; see qualified medical personnel and the safety director if you are exposed to or cut by broken tubes. Do not place radioactive tubes in your pocket. Use extreme care not to break radioactive tubes while handling them. Do not remove radioactive tubes from the cartons until ready to use them. Refer to paragraph 9-3 for handling, storage, and disposal of radioactive material.

Organizational, DS, GS, and Depot Maintenance Manual

VOLTMETER, ELECTRONIC AN/USM-98

	Paragraphs	Pages
CHAPTER 1. INTRODUCTION		
Section I. General	1-1-1-3	1-1
II. Description and data	1-4-1-7	1-1-1-2
CHAPTER 2. INSTALLATION AND OPERATING INSTRUCTIONS		
Section I. Service upon receipt of equipment	2-1, 2-2	2-1
II. Operation	2-3-2-10	2-3-2-8
CHAPTER 3. MAINTENANCE INSTRUCTIONS	3-1-3-15	3-1-3-6
4. FUNCTIONING OF VOLTMETER, ELECTRONIC AN/USM-98	4-1-4-6	4-4-4-11
6. TROUBLESHOOTING		
Section I. General troubleshooting techniques	5-1-5-3	5-1-5-2
II. Troubleshooting Voltmeter Electronic AN/USM-98	5-4, 5-5	5-3
III. Decade resistor fault isolation	5-6, 5-7	5-12, 5-13
CHAPTER 6. REPAIRS AND ALIGNMENT		
Section I. Repairs	6-1-6-7	6-1-6-3
II. Alignment	6-8, 6-9	6-3, 6-4
CHAPTER 7. GENERAL SUPPORT TESTING PROCEDURES	7-1-7-6	7-1-7-7
8. DEPOT OVERHAUL STANDARDS	8-1-8-10	8-1-8-3
9. SHIPMENT, LIMITED STORAGE, AND DEMOLITION TO PREVENT ENEMY USE		
Section I. Shipment and limited storage	9-1-9-3	9-1
II. Demolition of materiel to prevent enemy use	9-4, 9-5	9-1
APPENDIX A. REFERENCES		A-1
B. BASIC ISSUE ITEMS LIST (BI1) AND ITEMS TROOP INSTALLED OR AUTHORIZED LIST (ITIAL) (Not Applicable)		
C. MAINTENANCE ALLOCATION		C-1
GLOSSARY		G-1
INDEX		1-1

*This manual supersedes TM 11-6625-438-10, 26 October 1962, including C 1, 27 December 1963, and TM 11-6625-438-50, 20 February 1963, including C 1, .5 May 1964.



Figure 1-1. Voltmeter, Electronic AN/USM-98, less two-prong adapter and technical manuals.

**CHAPTER 1
INTRODUCTION**

Section I. GENERAL

1-1. Scope

This manual contains instructions for the operation, organizational, direct and general support, and depot maintenance of Voltmeter, Electronic AN/USM-98. Also included is the functioning of Voltmeter, Electronic AN/USM-98. Throughout this manual, Voltmeter, Electronic AN/USM-98 will be referred to as the voltmeter (vtvm).

1-2. Indexes of Publications

a. DA Pam 310-4. Refer to the latest issue of DA Pam 310-4 to determine whether there are new editions, changes, or additional publications pertaining to the equipment.

b. DA Pam 310-7. Refer to DA Pam 310-7 to determine whether there are modification work orders (MWO'S) pertaining to the equipment.

1-3. Forms and Records

a. Reports of Maintenance and Unsatisfactory Equipment. Maintenance forms, records, and reports which are to be used by maintenance personnel at all maintenance levels are listed in

and prescribed by TM 38-750.

b. Report of Packaging and Handling Deficiencies. Fill out and forward DD Form 6 (report of Packaging and Handling Deficiencies) as prescribed in AR 700-58 (Army)/NAVSUP Pub 378 (Navy)/AFR 71-4 (Air Force) MCO P4030.29 (Marine Corps), and DSAR 4145.8.

c. Discrepancy in Shipment Report (DISREP) (SF 361). Fill out and forward Discrepancy in Shipment Report (DISREP) (SF 361) as prescribed in AR 55-38 (Army)/NAVSUPINST 4610.33/AFM 75-18/MCO P4610.19A (Marine Corps), and DSAR 4500.15.

1-3.1. Reporting of Equipment Publication Improvements

The reporting of errors, omissions, and recommendations for improving this publication by the individual user is encouraged. Reports should be submitted on DA Form 2028 (Recommended Changes to Publications) and forwarded direct to Commander, US Army Electronics Command, ATTN: AMSEL-MA-C, Fort Monmouth, NJ 07703.

Section II. DESCRIPTION AND DATA

1-4. Purpose and Use

The vtvm is a portable, precision test equipment, used to measure voltages between 0 and 500 volts direct current (dc) and resistances between 1 and 500,000 megohms. Voltages may be measured by use of the vtvm either as a vacuum-tube voltmeter or as a differential voltmeter.

1-5. Technical Characteristics

a. Specifications, When Used as Vacuum-Tube Voltmeter (NULL switch in VTVM position).

Input voltage range	VOLTS RANGE setting	Input resistance (megohms)	Accuracy
0 to ±500V	5 0 0	10	Within ±490 on all ranges.
0 to ±50V	50	10	
0 to ±5v	5	10	
0 to ±0.5v	.5	10	

b. Specifications, When Used as Differential Voltmeter.

Input voltage range	VOLTS RANGE setting	Recommended NULL setting	Input resistance (ohms/volt)		Accuracy
			At null	At 1% off null (megohms)	
50-500	500	10	Infinite	100	Within ±0.05% of input voltage from 0.1 to 500 volts; within ±0.1% of input voltage or 0.5 millivolt (rev), whichever is greater, below 0.1 volt.
5-50	50	1	Infinite	1,000	
0.5-5	5	1	Infinite	1,000	
0-0.5	0.5	0.1	Infinite	1,000	
		0.1	Infinite	1,000	
		0.01	Infinite	10,000	
		0.1	Infinite	1,000	
		0.01	Infinite	10,000	

c. Resolution.

Voltage range	Direct through voltage-divider switches and indicators	Maximum volts meter resolution on most sensitive recommended null setting
0-500	10 mv	5 mv
0-50	1 mv	500 μv
0-5	100 μv	50 μv
0-0.5	10 μv	50 μv

d. Stability of Internal Reference Power Supply.

(1) Within 0.01 percent for change in line voltage (105 to 130 ac volts).

(2) Within 0.01 percent per hour after warmup. (This drift is adjustable through the front panel ADJ CAL control.)

e. Stability of VOLTS Meter. Within 4 percent of full scale for 20 percent change in line voltage; within 2 percent per hour after warmup (adjustable through the front panel ZERO controls).

f. Line-Voltage Input. 100-130 volts, 60 cycles.

g. Power Consumption. 60 watts.

h. Output to Recorder. 0.015 volt maximum.

i. Number of Tubes. 15

j. Weight. 28 pounds.

k. Radioactive Material.

Item	Isotope	Quantity (microcuries)
OA2 (tube type)	C060	0.0067
OB2 (tube type)	C060	0.0067

l. Temperature Range. 40° to 105°F. (4.5° to 40.5°C).

1-6. Components of Voltmeter, Electronic - AN/USM-98

(fig. 1-1)

The components of the vtvm are listed in the following chart:

Quantity	Item	Height in.	Depth in.	Width in.	Unit weight (lb)
1	Voltmeter, Electronic ME-161/U.	13	14	9-3/4	28
1	Test Lead sSet CX-1331/U.				1/4
1	Two-prong adapter.				
1	TM 11-6625-438-15.				

1-6.1. Items Comprising an Operable Equipment

Voltmeter, Electronic AN/USM-98 (FSN 6625-753-2115) and its components are shown in figure 1-1.

F S N QTY Nomenclature, part No., and mfr code

6625-753-2115		Voltmeter, Electronic AN/USM-98 consisting of:
6625-395-9313	1	Test Lead Set CX-1331/U
6625-753-2114	1	Voltmeter, Electronic ME-161/U

1-7. Description of Vtvm

a. All circuit components of the vtvm

are contained on a single chassis unit which slides into a grey metal case equipped with a leather carrying handle. The operating controls and the indicating meter are mounted on the front panel (fig. 1-1). The rear panel (fig. 1-2) contains the line power fuse, the output connections for an external recorder, and a gain adjustment for the recorder output.

b. The front and rear panels are part of the chassis assembly. Four rubber bumpers are

provided at the bottom of the case. Test Lead Set CX-1331/U (test leads) is supplied to provide connections for measuring voltage. One end of each test lead terminates in a standard-type banana plug for insertion in an input binding post on the vtvm. The other ends terminate in alligator clips which are connected

across the unknown voltage source being measured.

c. The power cord is fitted with a three-prong, polarized plug. A two-prong adapter with a grounding lead attached is provided for use with conventional, two-prong, power outlets.

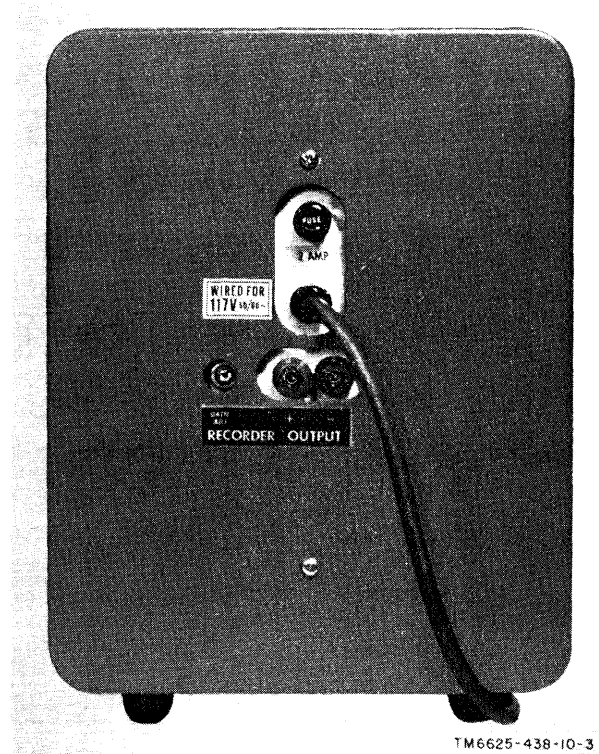

Figure 1-2. Voltmeter, Electronic AN/USM-98, rear view.

CHAPTER 2

INSTALLATION AND OPERATING INSTRUCTIONS

Section I. SERVICE UPON RECEIPT OF EQUIPMENT

2-1. Unpacking

a. Packaging Data. When packaged for shipment, the vtvm is placed in a corrugated carton the packed in a wooden packing case. A typical wooden packing case and its contents are shown in figure 2-1. The finished package is 18 1/4 inches high, 9 3/4 inches wide, 20 3/4 inches deep, and has a total volume of 2.13 cubic feet. The overall weight is 50 pounds.

b. Removing Contents.

Caution: Be careful when unpacking the equipment. Do not thrust tools into the interior of the shipping container; this procedure may damage the equipment.

- (1) Cut and fold back the metal straps.
- (2) Remove the nails from the wooden cover with a nailpuller and lift off the wooden cover.
- (3) Remove the outer corrugated carton that is wrapped in a moisture-proof barrier.
- (4) Open the outer corrugated carton and open the moisture-vaporproof barrier.

- (5) Remove and open the inner corrugated carton.
- (6) Remove the envelopes that contain the technical manuals, the two-prong adapter, and the test leads.
- (7) Remove the corrugated filters and the equipment from the inner corrugated carton.

2-2. Checking Unpacked Equipment

a. Inspect the equipment for damage incurred during shipment. If the equipment has been damaged, refer to paragraph 1-3.

b. Check to see that the equipment is complete as listed on the packing slip. If a packing slip is not available, check the items of the equipment against the table of components (para 1-6).

c. If the equipment has been used or reconditioned, check to see whether it has been changed by a modification work order (MWO). If modified, the MWO number will appear near the nomenclature plate.

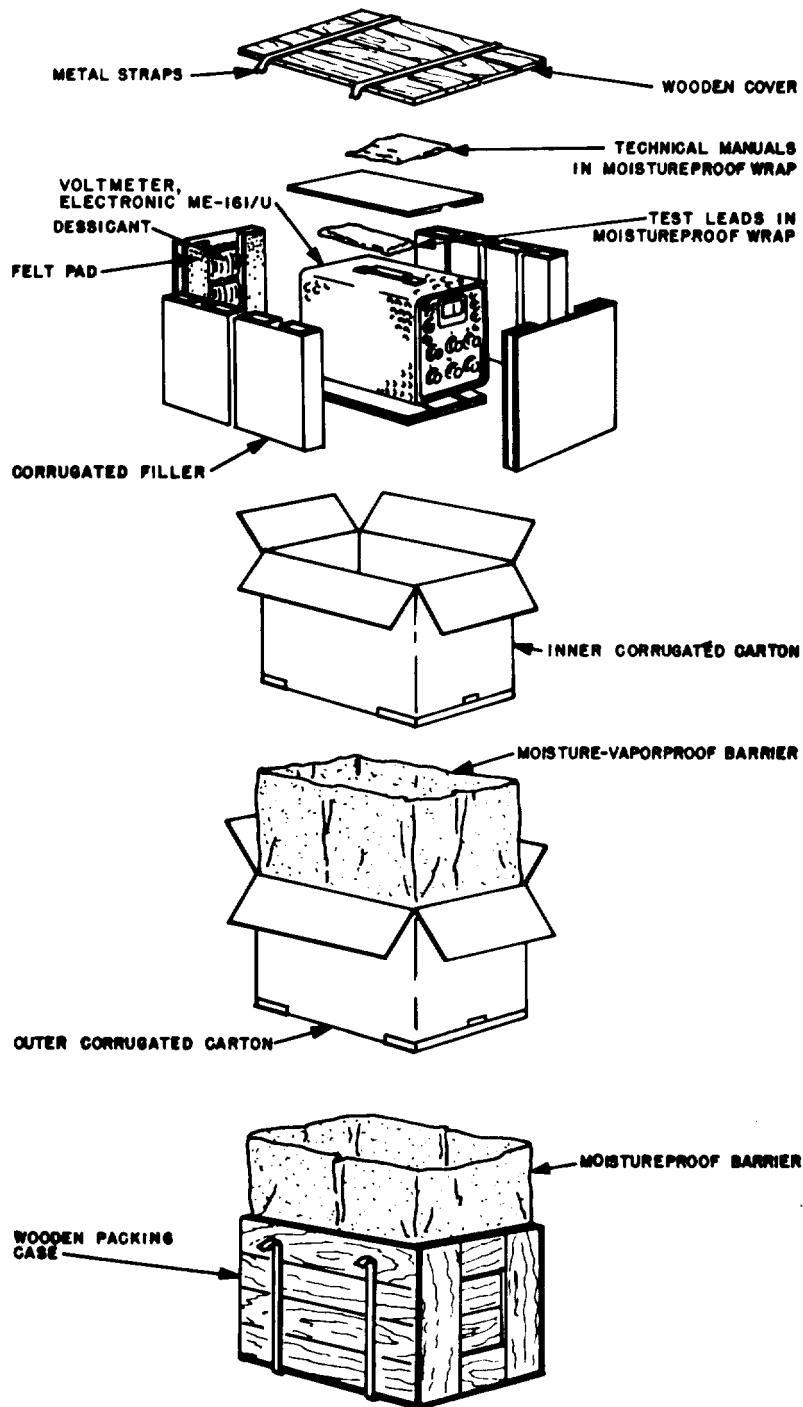

TM-6625-438-10-4

Figure 2-1. Typical packaging.

Section II. OPERATION

2-3. Voltmeter, Electronic AN/USM-98 Operating Controls and Indicators

(fig. 1-2 and 2-2).

Controls or indicators	Function			
G (chassis ground terminal).	Provides connection to chassis of ME-161/U.			
+ and - input terminals.	Provide connections for test leads.			
VOLTS RANGE switch (5-position rotary).	Selects internal reference power supply calibration or applied voltage.			
	<table border="0"> <thead> <tr> <th data-bbox="546 451 612 478">Sw pos</th> <th data-bbox="1096 451 1163 478">Action</th> </tr> </thead> </table>	Sw pos	Action	
Sw pos	Action			
	<table border="0"> <tr> <td data-bbox="546 485 612 512">CAL</td> <td data-bbox="612 485 1473 512">----- Permits internal reference power supply calibration, and isolates the input terminals.</td> </tr> </table>	CAL	----- Permits internal reference power supply calibration, and isolates the input terminals.	
CAL	----- Permits internal reference power supply calibration, and isolates the input terminals.			
	<table border="0"> <tr> <td data-bbox="546 519 612 546">500</td> <td data-bbox="612 519 1473 546">----- With NULL switch in VTVM position, selects voltage range of 0 to ± 500 volts.</td> </tr> </table>	500	----- With NULL switch in VTVM position, selects voltage range of 0 to ± 500 volts.	
500	----- With NULL switch in VTVM position, selects voltage range of 0 to ± 500 volts.			
	<table border="0"> <tr> <td data-bbox="546 553 612 580"></td> <td data-bbox="612 553 1473 580">With NULL switch in 10, 1, .1, or .01 position, selects the required internal-reference voltage in conjunction with voltage-divider switches A through E.</td> </tr> </table>		With NULL switch in 10, 1, .1, or .01 position, selects the required internal-reference voltage in conjunction with voltage-divider switches A through E.	
	With NULL switch in 10, 1, .1, or .01 position, selects the required internal-reference voltage in conjunction with voltage-divider switches A through E.			
	<table border="0"> <tr> <td data-bbox="546 587 612 614">50</td> <td data-bbox="612 587 1473 614">----- With NULL switch in VTVM position, selects voltage range of 0 to ± 50 volts.</td> </tr> </table>	50	----- With NULL switch in VTVM position, selects voltage range of 0 to ± 50 volts.	
50	----- With NULL switch in VTVM position, selects voltage range of 0 to ± 50 volts.			
	<table border="0"> <tr> <td data-bbox="546 621 612 649"></td> <td data-bbox="612 621 1473 649">With NULL switch in 10, 1, .1, or .01 position, selects the required internal-reference voltage in conjunction with voltage-divider switches A through E.</td> </tr> </table>		With NULL switch in 10, 1, .1, or .01 position, selects the required internal-reference voltage in conjunction with voltage-divider switches A through E.	
	With NULL switch in 10, 1, .1, or .01 position, selects the required internal-reference voltage in conjunction with voltage-divider switches A through E.			
	<table border="0"> <tr> <td data-bbox="546 655 612 683">5</td> <td data-bbox="612 655 1473 683">----- With NULL switch in VTVM position, selects voltage range of 0 to ± 5 volts.</td> </tr> </table>	5	----- With NULL switch in VTVM position, selects voltage range of 0 to ± 5 volts.	
5	----- With NULL switch in VTVM position, selects voltage range of 0 to ± 5 volts.			
	<table border="0"> <tr> <td data-bbox="546 689 612 717"></td> <td data-bbox="612 689 1473 717">With NULL switch in 10, 1, .1, or .01 position, selects the required internal-reference voltage in conjunction with voltage-divider switches A through E.</td> </tr> </table>		With NULL switch in 10, 1, .1, or .01 position, selects the required internal-reference voltage in conjunction with voltage-divider switches A through E.	
	With NULL switch in 10, 1, .1, or .01 position, selects the required internal-reference voltage in conjunction with voltage-divider switches A through E.			
	<table border="0"> <tr> <td data-bbox="546 723 612 751">.5</td> <td data-bbox="612 723 1473 751">----- With NULL switch in VTVM position, selects voltage range of 0 to ± 0.5 volts.</td> </tr> </table>	.5	----- With NULL switch in VTVM position, selects voltage range of 0 to ± 0.5 volts.	
.5	----- With NULL switch in VTVM position, selects voltage range of 0 to ± 0.5 volts.			
	<table border="0"> <tr> <td data-bbox="546 757 612 785"></td> <td data-bbox="612 757 1473 785">With NULL switch in 10, 1, .1, or .01 position, selects the required internal-reference voltage in conjunction with voltage-divider switches A through E.</td> </tr> </table>		With NULL switch in 10, 1, .1, or .01 position, selects the required internal-reference voltage in conjunction with voltage-divider switches A through E.	
	With NULL switch in 10, 1, .1, or .01 position, selects the required internal-reference voltage in conjunction with voltage-divider switches A through E.			
	<table border="0"> <tr> <td data-bbox="546 791 612 819"></td> <td data-bbox="612 791 1473 819">With VOLTS RANGE switch in CAL position and CAL PUSH switch depressed, permits internal-reference voltage calibration.</td> </tr> </table>		With VOLTS RANGE switch in CAL position and CAL PUSH switch depressed, permits internal-reference voltage calibration.	
	With VOLTS RANGE switch in CAL position and CAL PUSH switch depressed, permits internal-reference voltage calibration.			
	<table border="0"> <tr> <td data-bbox="546 825 612 853"></td> <td data-bbox="612 825 1473 853">Selects vacuum-tube voltmeter or differential voltmeter operation.</td> </tr> </table>		Selects vacuum-tube voltmeter or differential voltmeter operation.	
	Selects vacuum-tube voltmeter or differential voltmeter operation.			
	<table border="0"> <thead> <tr> <th data-bbox="546 859 612 887">Sw pos</th> <th data-bbox="1096 859 1163 887">Action</th> </tr> </thead> </table>	Sw pos	Action	
Sw pos	Action			
	<table border="0"> <tr> <td data-bbox="546 893 612 921">VTVM</td> <td data-bbox="612 893 1473 921">----- Permits vacuum-tube voltmeter operations.</td> </tr> </table>	VTVM	----- Permits vacuum-tube voltmeter operations.	
VTVM	----- Permits vacuum-tube voltmeter operations.			
	<table border="0"> <tr> <td data-bbox="546 927 612 955">10</td> <td data-bbox="612 927 1473 955">----- Permits differential voltmeter operation. (This position is recommended to measure ± 50 to 500 volts.)</td> </tr> </table>	10	----- Permits differential voltmeter operation. (This position is recommended to measure ± 50 to 500 volts.)	
10	----- Permits differential voltmeter operation. (This position is recommended to measure ± 50 to 500 volts.)			
	<table border="0"> <tr> <td data-bbox="546 961 612 989">1</td> <td data-bbox="612 961 1473 989">----- Permits differential voltmeter operation. (This position is recommended to measure ± 5 to 50 volts.)</td> </tr> </table>	1	----- Permits differential voltmeter operation. (This position is recommended to measure ± 5 to 50 volts.)	
1	----- Permits differential voltmeter operation. (This position is recommended to measure ± 5 to 50 volts.)			
	<table border="0"> <tr> <td data-bbox="546 995 612 1023">.1</td> <td data-bbox="612 995 1473 1023">----- Permits differential voltmeter operation. (This position is recommended to measure ± 0.5 to 5 volts.)</td> </tr> </table>	.1	----- Permits differential voltmeter operation. (This position is recommended to measure ± 0.5 to 5 volts.)	
.1	----- Permits differential voltmeter operation. (This position is recommended to measure ± 0.5 to 5 volts.)			
	<table border="0"> <tr> <td data-bbox="546 1029 612 1057">.01</td> <td data-bbox="612 1029 1473 1057">----- Permits differential voltmeter operation. (This position is recommended to measure 0 to ± 0.5 volt.)</td> </tr> </table>	.01	----- Permits differential voltmeter operation. (This position is recommended to measure 0 to ± 0.5 volt.)	
.01	----- Permits differential voltmeter operation. (This position is recommended to measure 0 to ± 0.5 volt.)			
	<table border="0"> <tr> <td data-bbox="546 1064 612 1091"></td> <td data-bbox="612 1064 1473 1091">Indicate decimal points when volt-divider indicators are being read. The indicator that lights depends on the position of the VOLTS RANGE switch as follows:</td> </tr> </table>		Indicate decimal points when volt-divider indicators are being read. The indicator that lights depends on the position of the VOLTS RANGE switch as follows:	
	Indicate decimal points when volt-divider indicators are being read. The indicator that lights depends on the position of the VOLTS RANGE switch as follows:			
	<table border="0"> <tr> <td data-bbox="546 1098 612 1125"></td> <td data-bbox="612 1098 1473 1125">VOLTS RANGE switch</td> <td data-bbox="959 1098 1285 1125">Decimal point indicator lamp lights.</td> </tr> </table>		VOLTS RANGE switch	Decimal point indicator lamp lights.
	VOLTS RANGE switch	Decimal point indicator lamp lights.		
	<table border="0"> <tr> <td data-bbox="546 1132 612 1159">500</td> <td data-bbox="612 1132 1473 1159">----- Between C and D.</td> </tr> </table>	500	----- Between C and D.	
500	----- Between C and D.			
	<table border="0"> <tr> <td data-bbox="546 1166 612 1193">50</td> <td data-bbox="612 1166 1473 1193">----- Left or C.</td> </tr> </table>	50	----- Left or C.	
50	----- Left or C.			
	<table border="0"> <tr> <td data-bbox="546 1200 612 1227">5</td> <td data-bbox="612 1200 1473 1227">----- Between A and B.</td> </tr> </table>	5	----- Between A and B.	
5	----- Between A and B.			
	<table border="0"> <tr> <td data-bbox="546 1234 612 1261">.5</td> <td data-bbox="612 1234 1473 1261">----- Left of A.</td> </tr> </table>	.5	----- Left of A.	
.5	----- Left of A.			
	<table border="0"> <tr> <td data-bbox="546 1268 612 1295"></td> <td data-bbox="612 1268 1473 1295">Indicate the value of internal-reference voltage applied.</td> </tr> </table>		Indicate the value of internal-reference voltage applied.	
	Indicate the value of internal-reference voltage applied.			
	<table border="0"> <tr> <td data-bbox="546 1302 1473 1330"></td> <td data-bbox="612 1302 1473 1330">A indicates 0, 1, 2, 3, or 4.</td> </tr> </table>		A indicates 0, 1, 2, 3, or 4.	
	A indicates 0, 1, 2, 3, or 4.			
	<table border="0"> <tr> <td data-bbox="546 1336 1473 1364"></td> <td data-bbox="612 1336 1473 1364">B indicates 0, 1, 2, 3, 4, 5, 6, 7, 8, or 9.</td> </tr> </table>		B indicates 0, 1, 2, 3, 4, 5, 6, 7, 8, or 9.	
	B indicates 0, 1, 2, 3, 4, 5, 6, 7, 8, or 9.			
	<table border="0"> <tr> <td data-bbox="546 1370 1473 1398"></td> <td data-bbox="612 1370 1473 1398">C indicates 0, 1, 2, 3, 4, 5, 6, 7, 8, or 9.</td> </tr> </table>		C indicates 0, 1, 2, 3, 4, 5, 6, 7, 8, or 9.	
	C indicates 0, 1, 2, 3, 4, 5, 6, 7, 8, or 9.			
	<table border="0"> <tr> <td data-bbox="546 1404 1473 1432"></td> <td data-bbox="612 1404 1473 1432">D indicates 0, 1, 2, 3, 4, 5, 6, 7, 8, or 9.</td> </tr> </table>		D indicates 0, 1, 2, 3, 4, 5, 6, 7, 8, or 9.	
	D indicates 0, 1, 2, 3, 4, 5, 6, 7, 8, or 9.			
	<table border="0"> <tr> <td data-bbox="546 1438 1473 1466"></td> <td data-bbox="612 1438 1473 1466">E indicates 0, 1, 2, 3, 4, 5, 6, 7, 8, 9, or 10.</td> </tr> </table>		E indicates 0, 1, 2, 3, 4, 5, 6, 7, 8, 9, or 10.	
	E indicates 0, 1, 2, 3, 4, 5, 6, 7, 8, 9, or 10.			
	<table border="0"> <tr> <td data-bbox="546 1472 612 1500"></td> <td data-bbox="612 1472 1473 1500">Indicate the value of internal-reference voltage applied.</td> </tr> </table>		Indicate the value of internal-reference voltage applied.	
	Indicate the value of internal-reference voltage applied.			
	<table border="0"> <tr> <td data-bbox="546 1506 612 1534"></td> <td data-bbox="612 1506 1473 1534">Indicate the value of internal-reference voltage applied.</td> </tr> </table>		Indicate the value of internal-reference voltage applied.	
	Indicate the value of internal-reference voltage applied.			
	<table border="0"> <tr> <td data-bbox="546 1540 612 1568"></td> <td data-bbox="612 1540 1473 1568">Indicate the value of internal-reference voltage applied.</td> </tr> </table>		Indicate the value of internal-reference voltage applied.	
	Indicate the value of internal-reference voltage applied.			
	<table border="0"> <tr> <td data-bbox="546 1574 612 1602"></td> <td data-bbox="612 1574 1473 1602">Indicate the value of internal-reference voltage applied.</td> </tr> </table>		Indicate the value of internal-reference voltage applied.	
	Indicate the value of internal-reference voltage applied.			
	<table border="0"> <tr> <td data-bbox="546 1608 612 1636"></td> <td data-bbox="612 1608 1473 1636">Indicate the value of internal-reference voltage applied.</td> </tr> </table>		Indicate the value of internal-reference voltage applied.	
	Indicate the value of internal-reference voltage applied.			
	<table border="0"> <tr> <td data-bbox="546 1642 612 1670"></td> <td data-bbox="612 1642 1473 1670">Indicate the value of internal-reference voltage applied.</td> </tr> </table>		Indicate the value of internal-reference voltage applied.	
	Indicate the value of internal-reference voltage applied.			
	<table border="0"> <tr> <td data-bbox="546 1676 612 1704"></td> <td data-bbox="612 1676 1473 1704">Indicate the value of internal-reference voltage applied.</td> </tr> </table>		Indicate the value of internal-reference voltage applied.	
	Indicate the value of internal-reference voltage applied.			
	<table border="0"> <tr> <td data-bbox="546 1710 612 1738"></td> <td data-bbox="612 1710 1473 1738">Indicate the value of internal-reference voltage applied.</td> </tr> </table>		Indicate the value of internal-reference voltage applied.	
	Indicate the value of internal-reference voltage applied.			
	<table border="0"> <tr> <td data-bbox="546 1744 612 1772"></td> <td data-bbox="612 1744 1473 1772">Indicate the value of internal-reference voltage applied.</td> </tr> </table>		Indicate the value of internal-reference voltage applied.	
	Indicate the value of internal-reference voltage applied.			
	<table border="0"> <tr> <td data-bbox="546 1779 612 1806"></td> <td data-bbox="612 1779 1473 1806">Indicate the value of internal-reference voltage applied.</td> </tr> </table>		Indicate the value of internal-reference voltage applied.	
	Indicate the value of internal-reference voltage applied.			

Controls or indicators	Function
Voltage-divider switches A through E.	Permit operator to adjust internal-reference voltage as required.
Power switch -----	When in ON position, turns equipment on.
VTVM-10V-1 ZERO control.	With VOLTS RANGE switch in the 500 position, NULL switch in VTVM, 10, or 1 position, permits adjustment to zero the VOLTS meter indicator.
.1V-.01V ZERO control --	With VOLTS RANGE switch in the 500 position, and NULL switch in .1 or 0.1 position, permits adjustment to zero the VOLTS meter indicator.
ADJ CAL control -----	With VOLTS RANGE switch in CAL position and CAL PUSH switch depressed, permits calibration of internal reference voltage.
VOLTS meter -----	When in vacuum-tube voltmeter operation, indicates the amplitude of voltage being measured.
	When in differential voltmeter operation, indicates the difference between the internal reference power supply voltage and the voltage being measured.
GAIN ADJ-RECORDER	Adjusts output of vtm to recorder terminals.
OUTPUT control	
(rear panel of ME-161/	
U, fig. 1-2).	
+ and - RECORDER	Provides connections for external recorder.
OUTPUT terminals	
(rear panel of ME-161/	
U, fig. 1-2).	

2-4. Types of Operation

Caution: If the vtm is tilted more than 45°, it must be set in a normal, upright position for a period of 48 hours before the vtm will regain its calibrated accuracy.

The vtm may be operated as a conventional, vacuum-tube voltmeter or as a differential voltmeter. It may be used to measure positive or negative voltages from 0 to 500 volts (paras 2-5 and 2-7), observe and record excursions of a voltage about a nominal value (paras 2-8 and 2-9) respectively, and measure high resistances between 1 and 500,000 megohms (para 2-10).

2-5. Starting Procedure

Caution: Be sure to ground the vtm chassis by connecting it to a three-prong receptacle. When only a conventional two-prong power out let is available, be sure to use the two-prong adapter and attach the grounding lead to the case of the conventional, two-prong power outlet.

a. Preliminary.

- (1) Set the power switch to the off (down) position.
- (2) Connect the power cord to a 115-volt, 60 cycle source.
- (3) Set the VOLTS RANGE switch to 500.
- (4) Set the NULL switch to VTVM.

- (5) Set all five voltage-divider switches to 0 on voltage-divider indicators A through E.
- (6) Set the power switch to ON.
- (7) Check for illumination of the decimal point indicator lamp between voltage-divider indicators C and D.
- (8) Allow the vtm to warm up for 5 minutes.
- (9) Zero the VOLTS meter indicator as described in *b* (1) through (7) below.

b. Zeroing VOLTS Meter.

Note. Maximum accuracy is obtained with the vtm only when the procedures for zeroing the VOLTS meter are carefully performed. Periodically check for zero indication during operation by disconnecting the test leads and repeating the procedures given below:

- (1) Set the VOLTS meter indicator to 0 by adjusting the VTVM-10V-1V ZERO control.
- (2) Check to see that the VOLTS meter indicator remains on 0 when the NULL switch is turned to positions 10 and 1.
- (3) Place the NULL switch to position .1.
- (4) Set the VOLTS meter indicator to 0 by adjusting the .1V-.01V ZERO control.
- (5) Check to see that the VOLTS meter indicator remains on 0 when the NULL switch is turned to position .01.

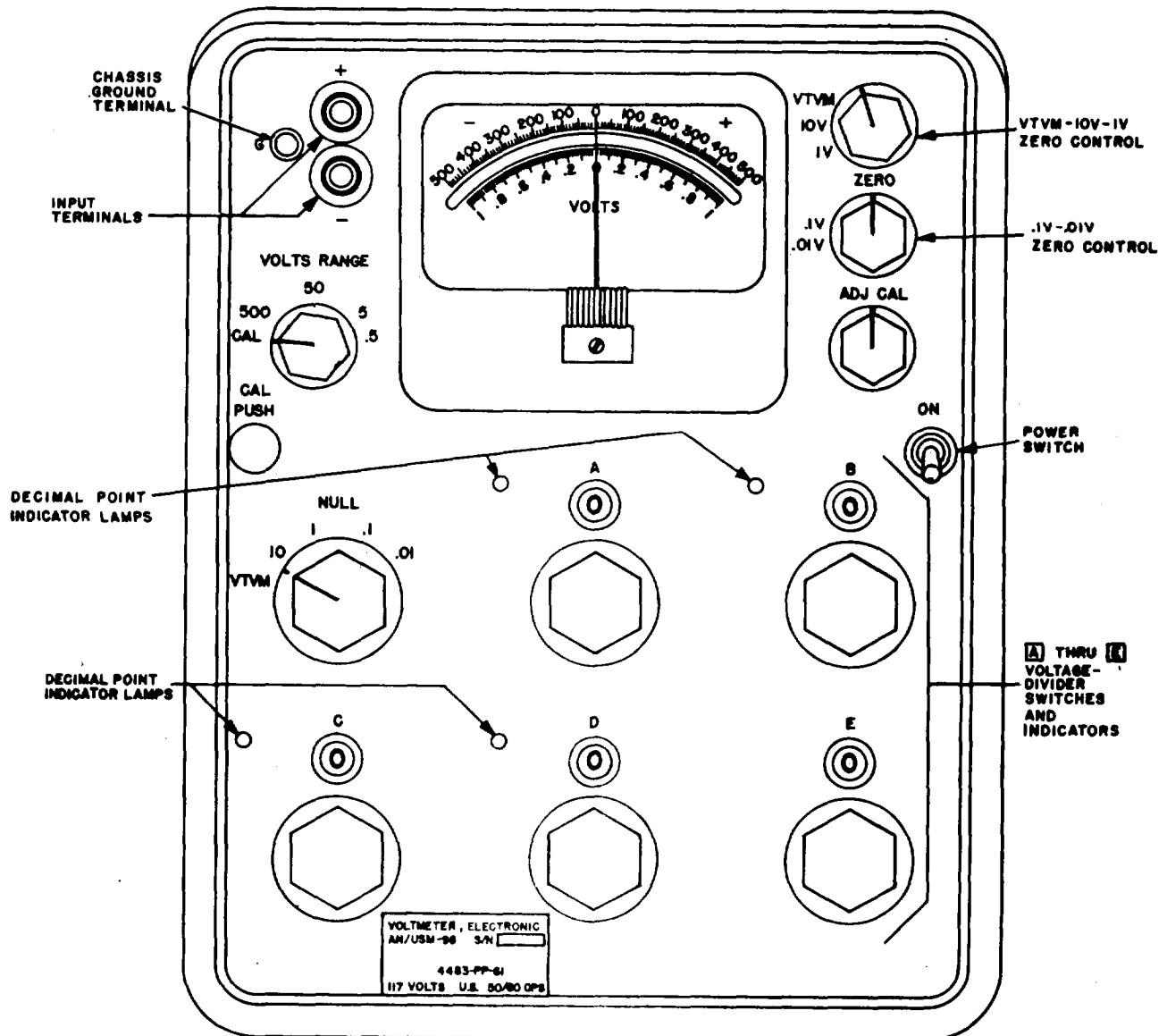

Figure 2-2. Voltmeter, Electronic ME-161/U, operating controls and indicators.

- (6) Set the VOLTS RANGE switch to CAL.
- (7) Depress the CAL PUSH switch and adjust the adj cal control until the VOLTS meter indicates 0.

2-6. Vacuum-Tube Voltmeter Operation

Caution: Be sure to bond the vivre 10 the unit to be measured either through the alter-

nating current (at) power source or by connecting a jumper (not supplied) between the G chassis ground terminal-on the vtm and the chassis of the unit to be measured.

Positive and negative voltages between 0 and 500 volts (within 4 percent accuracy) may be measured with the vtm used as a conventional, vacuum-tube voltmeter. Perform the starting procedure (para 2-5) and proceed as follows:

a. Set the VOLTS RANGE switch to 500, and the NULL switch to VTVM.

b. Connect the test leads to the + and - input terminal of the vtvm to the voltage source to be measured,

c. Turn on the voltage source to be measured.

d. Set the VOLTS RANGE switch to the lowest range that will give an on-scale indication. The VOLTS meter indication to the right indicates positive voltage, and the VOLTS meter indication to the left indicates negative voltage.

e. Determine the value of the voltage being measured direct from the VOLTS meter indication (upper scale).

2-7. Differential Voltmeter Operation

a. *General.* The vtvm is used as a differential voltmeter by comparison of the unknown voltage being measured with a known internal reference voltage. When the two voltages are equal, the VOLTS meter indicates 0. The magnitude of the known internal reference voltage, controlled by adjusting the voltage-divider switches A through E, is indicated direct on the voltage-divider indicators A through E. Therefore, the value of the unknown voltage being measured may be read directly on the voltage-divider indicators when the VOLTS meter indicates 0. When the voltage-divider switches are being adjusted, a VOLTS meter indicator deflection to the right indicates that

the unknown voltage is greater than the internal reference voltage, and the voltage-divider switch setting should be increased. The reverse is true if the VOLTS meter indicator deflects to the left. Perform the procedures given in b below to measure (within 0.05 percent accuracy) positive and negative unknown voltages between 0 and 500 volts.

b. Voltage Measurement (Differential Mode).

- (1) Determine the polarity and approximate value of the unknown voltage by using the vtvm as a conventional, vacuum-tube voltmeter (para 2-6). Leave the VOLTS RANGE switch in the lowest range that will give an on-scale indication. If the polarity of the voltage being measured is positive, proceed with the procedure given in (2) below. If the polarity of the voltage being measured is negative, reverse the test leads connected to the vtvm, check to see that the voltage being measured is negative, and perform the procedures given in (2) below.
- (2) Set voltage-divider switches A and B to correspond with the approximate value determined in (1) above, and set switches C, D, and E to zero; then set the VOLTS RANGE and NULL switches to the positions indicated in the chart below.

Approximate voltage	Setting of A	Setting of B	Setting of VOLTS RANGE switch	Setting of NULL switch
492 volts	4	9	500	10
155 volts	1	5	500	10
65 volts	0	6	500	10
36 volts	3	5	50	1
2.1 volts	2	0	5	.1
0.125 volt	1	2	.5	.01

Note. Set the voltage-divider switch slightly below the approximate value as indicated in the chart above.

Caution: When voltage divider switches A through E are rotated, the VOLTS meter indicator may swing to maximum deflection if the voltage applied is too high. Wait several minutes for the VOLTS meter indicator to stabilize.

- (3) Advance voltage-divider switch B until the VOLTS meter indicator deflects to the left, and then back one step to return the indicator to the right side.
- (4) Trim voltage-divider switches c through E as required to obtain a 0 indication on the VOLTS meter.

- (5) Determine the voltage being measured from the voltage-divider indicators; be careful to note the location of the decimal indication. For example, voltage-divider indicators A, B, C, D, and E indicate 3, 8, 6, 5, and 9, respectively. If the VOLTS RANGE switch were on 500 and the NULL switch on 10, the decimal point indicator between C and D would be illuminated and the voltage measured would be 386.59 volts. However, if the VOLTS RANGE switch were on 5, the NULL switch on .1, and the decimal point indicator between voltage-divider indicators A and B illuminated, the voltage reading would be 3.8659.
 - (6) Turn the NULL switch to VTVM.
 - (7) Turn off and disconnect the voltage under measurement from the input terminals.
- c. Ac Component.**
- (1) A low-pass filter is used in the .1 and .01 positions of the NULL switch to reduce any ac present on the dc being measured. This filter has an attenuation rate of 330 to 1 at 60 cycles per second (cps). A 0.5-volt ac component at 60 cps will be reduced to slightly over 0.001 volt. This may still cause a reading of as much as 10 percent of full scale when the NULL switch is set to .01, and may be negative or positive. If larger ac components are present, and the NULL switch is set to .1 or .01, additional filtering may be required.
 - (2) If the ac component is of a single frequency, a twin-T filter is effective and has the advantage of low total series resistance. If the ac components is of variable frequency an ordinary low-pass filter may be used. In either case, the capacitors used to form the filter should have a very high leakage resistance.
 - (3) Since the frequency and magnitude of the ac voltage components may vary from equipment to equipment, a specific filter cannot be specified here. Presumably, if a filter is required, it

will be specified in the technical manual covering the equipment under test. Losses introduced by the filter should be computed as specified in the equipment technical manual.

2-8. Observing Voltage Excursions

The vtvm can be used to observe excursions of a voltage about a given value, such as the variations in the output voltage of a dc power supply. Determine the approximate value of voltage to be observed by using the vtvm as a conventional, vacuum-tube voltmeter (para 2-6) and proceed as follows:

a. Reverse the test leads if the voltage under measurement is negative, and set the vtvm to operate as a differential voltmeter (para 2-7).

b. Observe the excursions directly on the VOLTS meter. The proper scale to use is indicated by the position of the NULL switch, as shown in the following chart:

NULL switch position	VOLTS meter (lower scale)
10	10-0-10
1	1-0-1
.1	.1-0-.1
.01	.01-0-.01

c. Increases in observed voltage are indicated by right deflection, and decreases by left deflection. For example, with the vtvm connected to a 450-volt dc power supply and set up to observe the excursions, the following conditions were observed: VOLTS RANGE switch at 500; NULL switch at 10; voltage divider switches A through E at 4, 4, 5, 5, and 0, respectively; VOLTS meter needle (varying) at .2-0-.2 on lower scale. This would indicate that the actual output of the dc power supply being observed was 445.5 volts dc. The excursions about the nominal voltage were ± 2 volts, which meant that the output voltage varied from 443.5 to 447.5 volts. This information would be used to determine that the output was stable within an allowable 1/2 of 1 percent. ----

d. Turn the NULL switch to VTVM.

e. Turn off and disconnect the voltage under measurement from the input terminals.

2-9. Recording Voltage Excursions

Provisions for connecting a recorder to the vtvm are included on the rear panel. If a recorder is to be used to record excursions, carefully perform the following procedures:

a. Select a recorder with at least 500,000 megohms resistance between the recorder and the ground.

b. Check to see that RECORDER OUTPUT + and - terminals on the rear panel of the vtvm are isolated from the ground.

c. Connect the recorder with teflon leads and make the following checks:

- (1) Connect a standard cell between the + and - input terminals on the front panel of the vtvm.
- (2) Measure the standard cell potential.
- (3) Alternately connect and disconnect the recorder leads.
- (4) Check to see that there is not more than one-fourth of a small division deflection of the VOLTS meter indicator.

Note. Excessive VOLTS meter indicator deflection as the recorder is connected and disconnected indicates that leakage has been introduced by the recorder. This condition can only be remedied by utilizing another recorder.

- (5) Zero the VOLTS meter indicator as given in paragraph 2-5 b.
- (6) Place the VOLTS RANGE switch at 500, the NULL switch at 1, and all five voltage-divider switches at 0.
- (7) Turn the voltage-divider switches to indicate 400 volts; check to see that there is no more than one-fourth of a small division deflection of the VOLTS meter indicator as the voltage-divider switches are rotated.

Note. Excessive deflection of the VOLTS meter indicator may be caused by leakage in either the recorder or the vtvm. Disconnect the recorder and repeat the procedures given in (5), (6), and (7) above to isolate the source of leakage. If the source of leakage is the recorder, use another recorder. If the source of leakage is the vtvm, repair of the vtvm is required by a higher maintenance repair category.

- (8) Set up the vtvm to observe the excursions of a voltage (para 2-8).

- (9) Adjust the GAIN ADJ control on the back panel of the vtvm for the desired amount of recorder deflection (0.015 volt maximum).
- (10) When the recording has been completed, turn off and disconnect the voltage under measurement from the + and - input terminals, and the teflon leads from the RECORDER OUTPUT + and - terminals.

2-10. Measuring High Resistance

Perform the following procedures to determine the value of an unknown resistance between 1 and 500,000 megohms.

a. 1 Megohm to 500,000 Megohms.

- (1) Place the VOLTS RANGE switch at 500, and the NULL switch at either 10 or 1.
- (2) Zero the VOLTS meter with the VTVM-10V-1V ZERO control.
- (3) Place a jumper wire (not supplied) between the - input terminal and the G chassis ground terminal.
- (4) Connect the resistance under measurement between the + and - input terminals by use of *short, insulated leads*. Be sure to connect the - input terminal to the grounded or low side of the resistance under measurement.

Caution: The vtvm can easily measure the leakage of long, twisted leads that cause erroneous indications.

- (5) Adjust the five voltage-divider switches (A through E) until the VOLTS meter indicator is deflected to a point easy to read.
- (6) Record the VOLTS meter indication, the voltage-divider indicators (A through E) indication, and the NULL switch position, and substitute the values in the following equation to determine the resistance:

$$R_x = 10^7 \left(\frac{E}{EM} - 1 \right) \text{ where—}$$

R_x is the unknown resistance in ohms,

E is the voltage-divider indicators (A through E) indication, and EM is the VOLTS meter reading.

Note. When the NULL switch is set to 10, the lower scale indicates 10-0-10. When the NULL switch is set to 1, the lower scale indicates 1-0-1.

- (7) Remove the resistance under measurement and the jumper wire from the terminals.

b. Rapid Measurement of 1 Megohm to 500 Megohms.

- (1) Place the VOLTS RANGE switch at 500, and the NULL switch at 10.
- (2) Zero the VOLTS meter with the VTVM-10V-1V ZERO control.
- (3) Place a jumper wire between the - input terminal and the G chassis ground terminal.
- (4) Connect the resistance under measurement between the + and - input terminals by use of *short, insulated leads*. Be sure to connect the - input terminal to the grounded or low side of the resistance under measurement.
- (5) Adjust the five voltage-divider switches (A through E) for full-scale VOLTS meter indicator deflection.
- (6) Record the voltage-divider indicators (A through E) indication, and sub

tract 10 from the recorded value. T is the value of the unknown resists in megohms. For example, if the corded value is 433.22, subtract 10; the value of the resistance is 423.22 megohms.

- (7) Remove the resistance under measurement and the jumper wire from the terminals.

c. Rapid Measurement of 1 Megohm to 5,000 Megohms.

- (1) Place the VOLTS RANGE switch at 500, and the NULL switch at 1.
- (2) Zero the VOLTS meter with the VTVM-10V-1V ZERO control.
- (3) Place a jumper wire between the - input terminal and the G chassis ground terminal.
- (4) Connect the resistance under measurement between the + and - terminals by use of *short, insulated leads*.
- (5) Adjust the five voltage-divider switches (A through E) for full-scale VOLTS meter indicator deflection.
- (6) Record the voltage-divider indicators (A through E) indication, subtract 1, and multiply the difference by 10. This is the value of the unknown resistance in megohms.
- (7) Remove the resistance under test and the jumper wire from the terminals.

CHAPTER 3

MAINTENANCE INSTRUCTIONS

3-1. Scope of Maintenance

The maintenance duties assigned to the operator and the organizational repairman of the equipment are listed below together with a reference to the paragraphs covering the specific maintenance function. The tools and test equipment required are listed in appendix C.

- a. Operator's daily preventive maintenance checks and services (para 3-4).
- b. Organizational weekly preventive maintenance checks and services (para 3-5).
- c. Organizational monthly preventive maintenance checks and services (para 3-6).
- d. Organizational quarterly preventive maintenance checks and services (para 3-7).
- e. Cleaning (para 3-8).
- f. Touchup painting (para 3-9).
- g. Visual inspection (para 3-10).
- h. Equipment performance (para 3-11).
- i. Replacement of fuse (para 3-12).
- j. Replacement of tubes (para 3-13).
- k. Replacement of decimal point indicator lamps (para 3-14).
- l. Replacement of meter protective fuse (para 3-15).

3-2. Preventive Maintenance

Preventive maintenance is the systematic care, servicing, and inspection of equipment to prevent the occurrence of trouble, to reduce downtime, and to assure that the equipment is serviceable.

a. *Systematic Care.* The procedures given in paragraphs 3-4 through 3-8 cover routine systematic care and cleaning essential to proper upkeep and operation of the equipment.

b. *Preventive Maintenance Checks and Services.* The preventive maintenance checks and services charts (paras 3-4 through 3-7) outline functions to be performed at specific intervals. These checks and services are to maintain Army electronic equipment in a combat-serviceable condition; that is, in good general (physical) condition and in good operating condition. To assist operators in maintaining combat serviceability, the charts indicate what to check, how to check, and what the normal conditions are; the *References* column lists the paragraphs or manuals that contain detailed repair or replacement procedures. If the defect cannot be remedied by performing the corrective actions listed, higher category maintenance or repair is required. Records and reports of these checks and services must be made in accordance with the requirements set forth in TM 38-750.

3-3. Preventive Maintenance Checks and Services Periods

Preventive maintenance checks and services of the equipment are required daily, weekly, monthly, and quarterly.

a. Paragraph 3-4 specifies the checks and services that must be accomplished daily (or at least once each week if the equipment is maintained in standby condition).

b. Paragraphs 3-5, 3-6, and 3-7 specify *additional* checks and services that must be performed on a weekly, monthly, and quarterly basis, respectively.

3-4. Operator's Daily Preventive Maintenance Checks and Services Chart

Sequence No.	Item to be Inspected	Procedure	References
1	Completeness -----	See that the equipment is complete (appx B).	None.
2	Exterior surfaces -----	Clean the exterior surfaces, including the panel and meter glaas (pars 3-8 a). Check the meter glass and indicator lenses for cracks.	None.
3	Connectors -----	Check the tightness of all connectors --	None.
4	Controls and indicators ----	While making the operating checks (item 5), check to see that the mechanical action of each knob and switch is smooth and free of external or internal binding, and that there is no excessive looseness. Also check the meter for sticking or bent pointer.	
5	Operation -----	During operation, be alert for any unusual performance or condition.	None.

3-5. Organizational Weekly Preventive Maintenance Checks and Services Chart

Sequence No.	Item to be Inspected	Procedure	References
1	Cables -----	Inspect cords, cables, and wires for chafed, cracked, or frayed insulation. Replace connectors that are broken, arced, stripped, or worn excessively.	None.
2	Handle -----	Inspect handle for looseness. Replace or tighten as necessary.	None.
3	Metal surfaces -----	Inspect exposed metal surfaces for rust and corrosion. Clean and touchup paint as required (para 3-9).	None.
4	Battery and compartment ----	Inspect the battery for loose terminals and leakage. Check the compartment for corrosion.	None.

3-6. Organizational Monthly Preventive Maintenance Checks and Services Chart

Sequence No.	Item to be Inspected	Procedure	References
1	Pluckout items -----	Inspect seating of pluckout items. Make sure that tube clamps grip tube bases tightly.	
2	Jacks -----	Inspect jacks for snug fit and good contact.	
3	Transformer terminals -----	Inspect terminals on power transformer. All nuts must be tight. There should be no evidence of dirt or corrosion.	
4	Terminal blocks -----	Inspect terminal blocks for loose connections and cracked or broken insulation.	
5	Resistors and capacitors -----	Inspect resistors and capacitors for cracks, blistering, or other detrimental defects.	
6	Gaskets and insulators -----	Inspect gaskets, insulators, bushings, and sleeves for cracks, chipping, and excessive wear.	
7	Interior -----	Clean interior of chassis and cabinet --	Para 3-8.

3-7. Organizational Quarterly Preventive Maintenance Checks and Services Chart

Sequence No.	Item to be Inspected	Procedure	References
1	Publications -----	Check to see that all publications are complete, serviceable, and current.	DA Pam 3104
2	Modifications -----	Check DA Pam 310-4 to determine if new applicable MWO'S have been published. All URGENT MWO'S must be applied immediately. All NORMAL MWO'S must be scheduled.	TM 38-750 and DA Pam 310-4.
3	Spare parts -----	Check all parts (operator and organizational) for general condition and method of storage. No overstock should be evident, and all shortages must be on valid requisitions.	Appx B.

3-8. Cleaning

a. *Exterior of Equipment.* Inspect the exterior of the equipment. The exterior surfaces should be free of dust, dirt, grease, and fungus.

- (1) Remove the dust and the loose dirt with a clean, soft cloth.

Warning: Cleaning Compound (FSN 7930-395-9542) is flammable and its fumes are toxic. Provide adequate ventilation. Do not use near a flame.

- (2) Remove the grease, the fungus, and the ground-in dirt from the case; use a cloth dampened (not wet) with the cleaning compound.
- (3) Remove the dust or the dirt from the plugs and the jacks with a brush.

Caution: Do not press on the meter face (glass) when cleaning; the meter may become damaged.

- (4) Clean the front panel, the meter, and the control knobs; use a soft, clean cloth. If dirt is difficult to remove, dampen the cloth with water; mild soap may be used for more effective cleaning.

b. *Interior of Equipment.* Perform the procedures given in (1) through (5) below to remove the dust and any foreign matter and to prevent leakage.

- (1) Remove the two securing screws at the rear of the vtvm and pull the chassis out of the case.
- (2) Blow out the dust and any foreign matter from the vtvm with a low-

pressure dry air blower. Be sure that the binding posts, the wiring, and all the switches are completely free of dust and foreign matter.

- (3) Clean the binding posts, the insulators, and the front panel with a rag saturated in anhydrous denatured ethyl alcohol.

Caution: Use only anhydrous denatured ethyl alcohol when cleaning the insulators of the switches. Other cleaning solvents may react with the insulating material in these switches.

- (4) When necessary, wash the exposed insulating material of all switches with a small, stiff, bristled brush and the anhydrous denatured ethyl alcohol.
- (5) After washing, recoat the exposed switch insulating material with a solution of Dow Corning 200 having a viscosity between 50 and 200 centistokes (10 percent solution of 100 viscosity grade Dow Corning 200 in anhydrous denatured ethyl alcohol). This solution will prevent any leakage due to moisture on these surfaces. Do not apply grease or other lubricants to switch wafers.

3-9. Touchup Painting Instructions

Remove rust and corrosion from metal surfaces by lightly sanding them with fine sandpaper. Brush two thin coats of paint on the bare metal to protect it from further corrosion.

Refer to the applicable cleaning and refinishing practices specified in TB SIG 364.

3-10 Visual Inspection

When the equipment fails to operate properly, turn off the power and check for the conditions listed below. Inspection will save repair time and may also avoid further damage. *Do not check any item with the power on.*

- a. Wrong settings of switches and controls.
- b. Damaged, disconnected, or poorly connected power cord.
- c. Burnt-out fuse. (This condition usually indicates some other fault.)

3-11. Troubleshooting

a. *General.* The troubleshooting chart (b below) provides a procedure for the systematic check of equipment performance. All the corrective measures that the repairman can perform are given in the *Corrective measures* column. When using the troubleshooting chart, follow each step in the order given. If the corrective measures indicated do not restore the equipment performance, troubleshooting is required by a higher maintenance repair category. Note on the repair tag how the equipment performed and the corrective measures that were taken.

b. Troubleshooting Chart.

Step	Item	Action or condition	Normal indication	Corrective measures
1	Power switch and decimal point indicator lamps.	Set power switch to ON, and set VOLTS RANGE switch to 500, 5, and .5.	All decimal point indicator lamps light in sequence.	Check connector plug on power cord, Check 2 ampere fuse on rear panel. Refer to paragraph 3-12.
2	VOLTS meter and null circuits.	Set VOLTS RANGE switch to 500, NULL switch to VTVM, and all voltage-divider switch ± 0 . Rotate VTVM-10V-1V ZERO control.	VOLTS meter indicator can be set to 0.	Higher maintenance category repair required.
3	VOLTS meter and null circuits.	Set NULL switch to 10, and rotate VTVM-10V-1V ZERO control.	VOLTS meter indicator can be set to 0.	Check V104; higher maintenance category repair required if V104 is defective. Check V105 and V100; replace if necessary.
4	VOLTS meter and null circuits.	Set NULL switch to 1, and rotate VTVM-10V-1V ZERO control.	VOLTS meter can be set to 0.	Check V104; higher maintenance category repair required if defective. Check V105 and V100; replace if necessary.
5	VOLTS meter and null circuits.	Set NULL switch to 1, and rotate VTVM-10V-1V ZERO control.	VOLTS meter can be set to 0.	Check V104; higher maintenance category repair required if defective. Check V105 and V100; replace if defective.
6	VOLTS meter and null circuits.	Set NULL switch to .01, and rotate VTVM-10V-1V ZERO control.	VOLTS meter can be set to 0.	Check V104; higher maintenance category repair required if defective. Check V105 and V100; replace if defective.

Step	Item	Action or condition	Normal indication	Corrective measures
7	Calibrate; 500-volt reference power supply.	Adjust ADJ CAL control for zero deflection of VOLTS meter. Set VOLTS RANGE to CAL; depress CAL PUSH.	Volts meter can be set to 0.	Check V1, V2, V3, V4, V5, V7, and V8; replace if defective. Check V6; if defective, higher maintenance category repair required.
8	VOLTS meter calibration.	Meter drifts from CAL setting every 5 or 10 minutes. Adjust ADJ CAL control to zero, as in step 7.	VOLTS meter can be set to 0, and does not drift.	Check V7 and V8; replace if defective. Check V6; higher maintenance category repair required if defective.
9	VOLTS meter rattle.	NULL switch set to 10, 1, .1, and .01.	VOLTS meter indicator at 0, and does not rattle.	Check V1, V8, V100, V102, and V103; replace if faulty.
10	Leakage-----	Set VOLTS RANGE switch to 500, NULL switch to 1, and voltage-divider switches to 400.00.	VOLTS meter indicates not more than 50 (on upper scale) to the left.	Clean interior of equipment (para 3-8).

3-12. Replacement of Fuse

If the vtvm is completely inoperative, the fuse (2-ampere) is probably defective. Replace the defective fuse with a new one. If the new fuse blows when power is applied, repair at higher maintenance category is required. Replace the fuse as follows:

- a. Turn the fuseholder cap on the rear panel counterclockwise to unlock the cap.
- b. Pull out the fuseholder cap and the defective fuse.
- c. Remove the defective fuse and replace it with a new one.

3-13. Replacement of Tubes
(fig. 3-1)

Warning: Tubes 0A2 and OB2 contain radioactive material. Handle them carefully to avoid breaking.

Caution: Do not rock or rotate a tube when removing it from its socket; use a tube puller and pull the tube straight out.

a. *General.* Before replacing any tubes, check the power cord and the fuses as the possible source of the trouble. If the trouble is not found, follow the instructions given in b and c below to check the tubes.

b. *Use of Tube Tester.* Remove and test one tube at a time. Discard a tube only if the defect is obvious or the tube tester shows it to be defective. Do not discard a tube that tests at or

near its minimum test limit. Replace the original tube, or insert a new one if required, before testing the next one.

c. *Tube Substitution Method.* Replace a suspected tube with a new tube. If the equipment still does not work, remove the new tube and put back the original tube. Repeat this procedure with each suspected tube until the defective tube is located.

Note. This method will not work when more than one tube is defective in the same circuit.

3-14. Replacement of Decimal Point Indicator Lamp

a. Remove the two securing screws at the rear of the vtvm.

b. Pull the chassis out of the case.

c. Press the sides of the lampholder (located at the rear of front panel PL1, PL2, PL3, or PL4 (figs. 2-2 and 5-8)) together and remove the lampholder from the mounting plate.

d. Remove the paper shield from the decimal point indicator lamp.

e. Press in on the decimal point indicator lamp and turn it counterclockwise to unlock.

f. Pull the defective indicator lamp out and replace it. Press the new decimal point indicator lamp into the socket and turn it clockwise to lock.

g. Replace the paper shield and press the sides of the lampholder to insert it in the mounting plate.

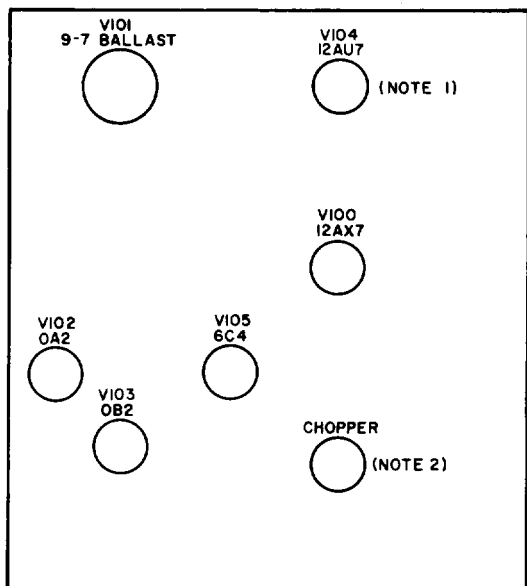

A. CHOPPER AMPLIFIER PRINTED CIRCUIT BOARD.

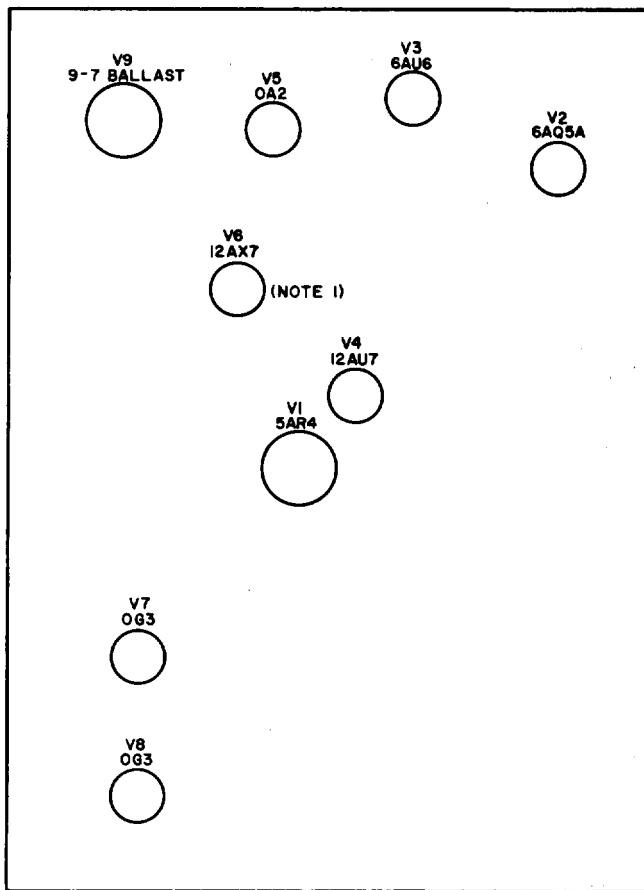

B. REFERENCE SUPPLY PRINTED CIRCUIT BOARD.

TM6625-438-12-1

NOTES:

1. TUBES V6 AND V104 MUST BE SELECTED, BY HIGHER LEVEL MAINTENANCE
2. CHOPPER MUST BE TESTED AND REPLACED BY HIGHER LEVEL MAINTENANCE

Figures 3-1. Voltmeter, Electronic AN/USM-98, tube location.

h. Replace the chassis in the case and secure it with the two screws.

3-15 Replacement of Meter Protective Fuse

a. Remove the two securing screws at the rear of the vtvm.

b. Pull the chassis out of the case.

c. Replace meter protective fuse F2 (fig. 5-8) located at the rear of the front panel.

d. Replace the chassis in the case and secure it with the two screws.

CHAPTER 4

FUNCTIONING OF VOLTMETER, ELECTRONIC AN/USM-98

4-1. Internal Differences in Models

Internal differences exist in the low-pass filter used in the 500-volt reference power supply. In Voltmeter, Electronic AN/USM-98, serial numbers 1 through 145, the filter consists of R1, C1, and C2; and for serial numbers 146 through 218, the filter consists of R1, R71, R72, R73, C10, C11, and C12.

4-2. Block Diagram

(fig. 4-1)

Voltmeter, Electronic AN/USM-98 is a precision voltmeter used to accurately measure direct current potentials from 0 to 500 volts. The vtm contains a balanced bridge (*a* below), a 0- to 500-volt reference power supply (*b* below), a 60-cycle chopper amplifier (*c* below), and a low-voltage power supply (*d* below). The vtm functions as a vacuum-tube voltmeter when the NULL switch is set to VTVM, and as a differential voltmeter when the NULL switch is set to 10, 1, .1, or .01.

a. Balanced Bridge (figs. 4-1 and 4-2).

- (1) The voltage being measured is applied to the + and - input terminals and appears across the balanced bridge (fig. 4-2) consisting of an active tube (V104A), an inactive balancing tube (V104B), a meter (M1), and a zero-balancing network. In the differential voltmeter mode (NULL switch set to 10, 1, .1, or .01), the balanced bridge causes meter M1 to indicate the difference between the 0- to 500-volt reference power supply and the unknown voltage (voltage being measured). In the vacuum-tube voltmeter mode (NULL switch set to VTVM), the balanced

bridge causes meter M1 to indicate the unknown voltage directly.

- (2) When using the vtm to measure high resistance (from 1 to 500,000 megohms), the resistance being measured is connected to the input terminals of the vtm. The equipment is operated in the differential voltmeter mode (NULL switch set to 10 or 1) and voltage-divider switches A through E are adjusted to apply sufficient internal reference voltage across the unknown resistance to cause meter M1 to indicate off null. This off-null reading is noted and the resistance is computed in megohms.

b. 0- to 500-Volt Reference Power Supply (figs. 4-1 and 4-3). The 0- to 500-volt reference voltage is obtained from a +500-volt power supply and a voltage divider. A part of power transformer T1 and power rectifier tube V1 provide unregulated +900 volts. First series regulator tube V2, control amplifier tube V3, and voltage reference tube V5 provide regulated +625 volts. Second series regulator tube V4A, control amplifier tube V4B, differential amplifier tube V6, and voltage reference tubes V7 and V8 provide regulated +500 volts. The reference range voltage divider, VOLTS RANGE switch, and the five-decade attenuator provide the desired voltage (0 to 500 volts). This voltage is applied to the grid of V104B.

c. 60-Cycle Chopper Amplifier (figs. 4-1 and 4-4). The 60-cycle chopper amplifier is a stable, drift-free, dc amplifier with a gain of 50, and the 60-cycle chopper (CK1) is used to convert the input voltage to a square wave. The input voltage to the 60-cycle chopper amplifier is the difference between the 0- to 500-volt reference power supply output and the un-

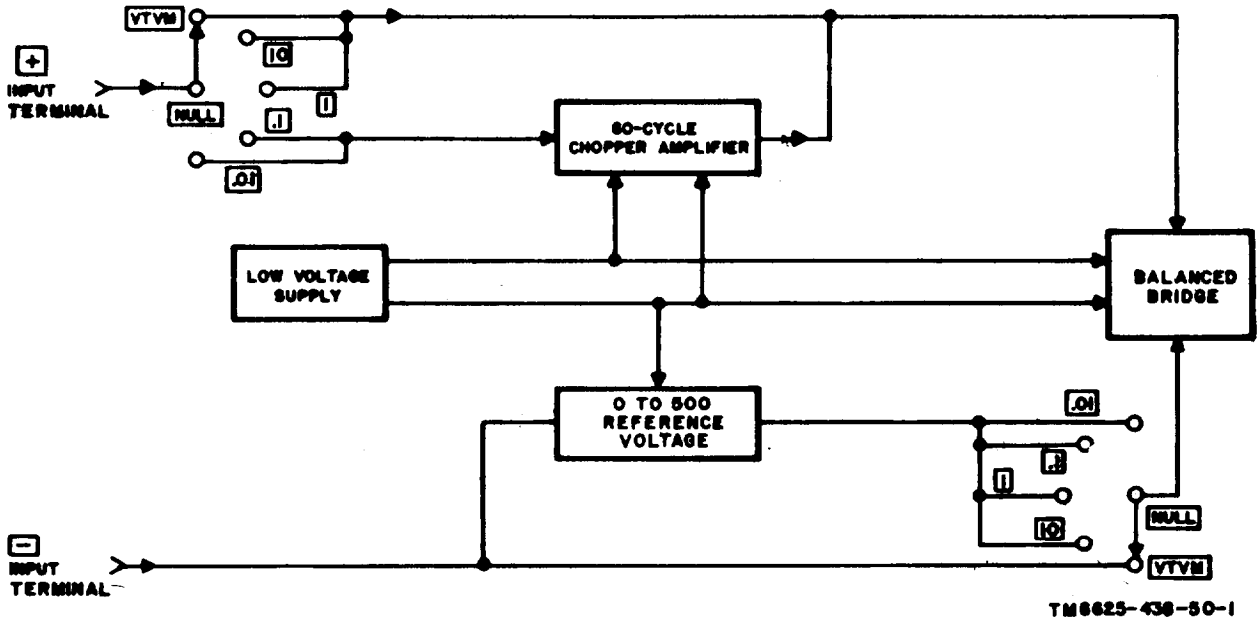

Figure 4-1. Voltmeter, Electronic AN/USM-98, block diagram.

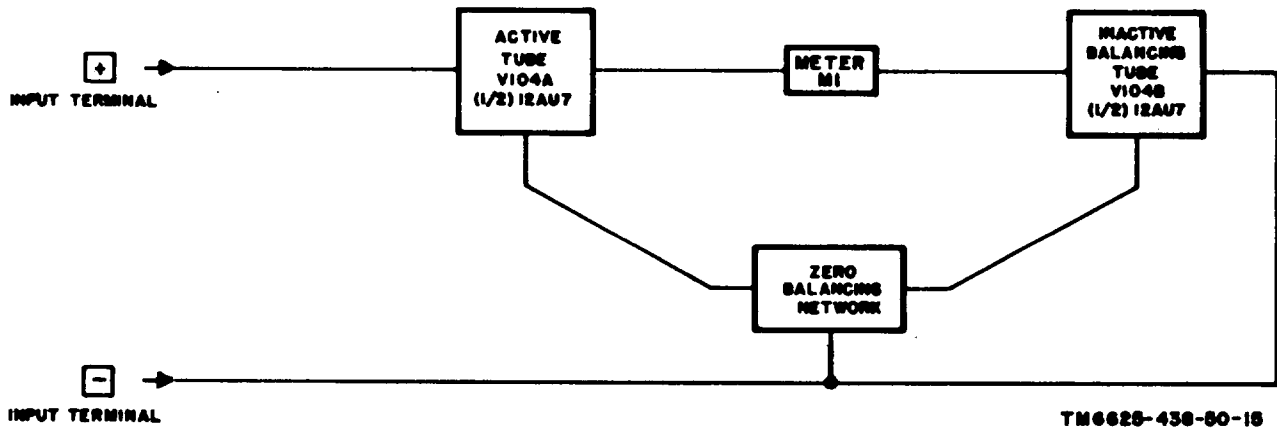

Figure 4-2. Balanced bridge, block diagram.

known voltage when the NULL switch is set to .1 or .01. The square wave is passed through two stages of amplification (V100A and V100B) and an inverter stage (V105), and then synchronously rectified by the 60-cycle chopper. The dc output of inverter stage V105 is coupled to the grid of V104A.

d. Low-Voltage Power Supply (figs. 4-1 and 4-5). The low-voltage power supply consists

of a part of power transformer T1, low-voltage rectifiers CR1 and CR2, and voltage regulator tubes V102 and V103 to provide regulated +110 volts to tubes V100, V104, and V105; seven filament windings of power transformer T1 to provide filament voltage for tubes V1, V2, V3, V4, V6, V100, V104, V105, decimal point indicator lamps PL1, PL2, PL3, PL4, and 60-cycle chopper CK1; ballast tubes V9 and V101 to provide current regulation of filament

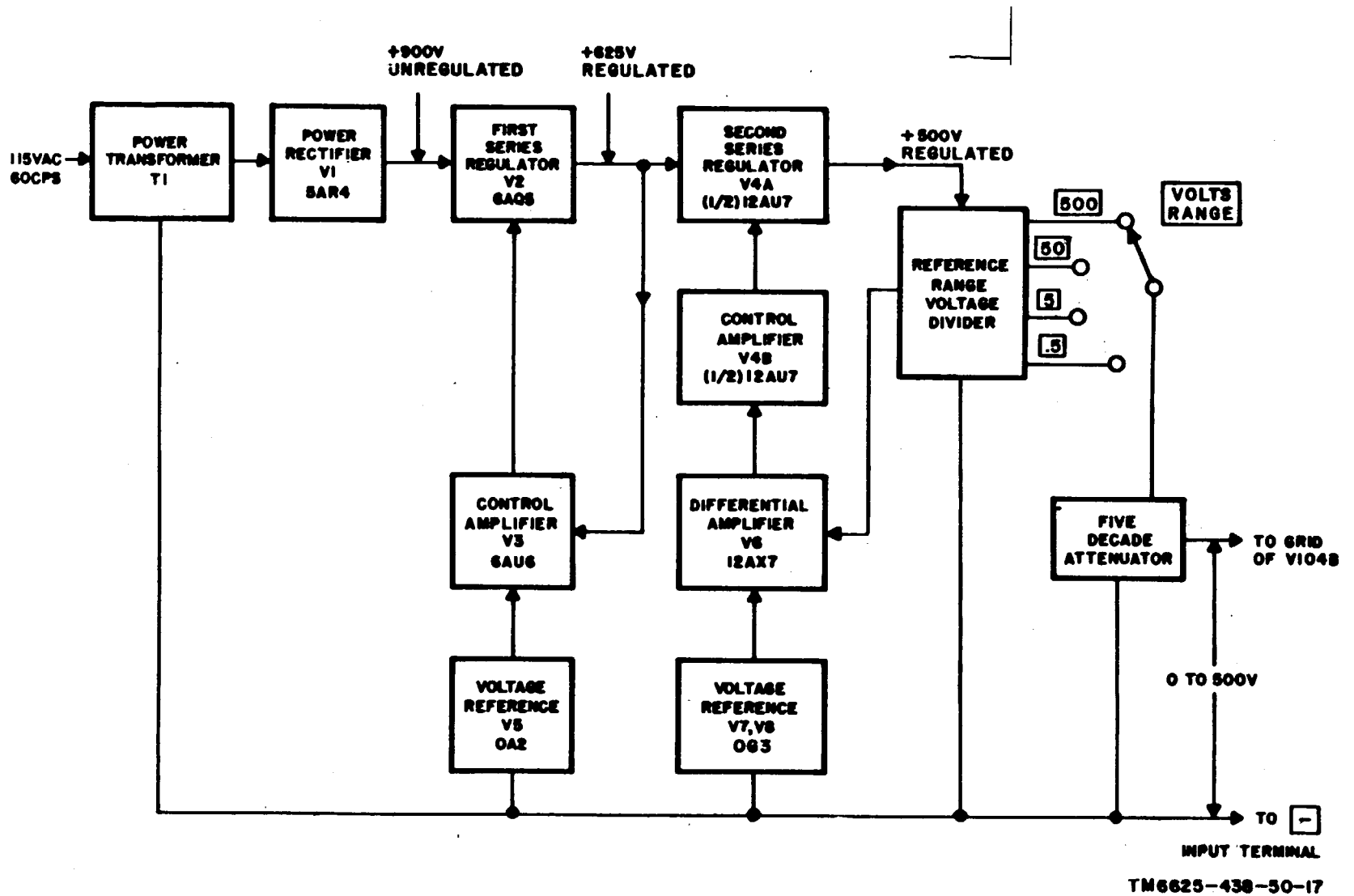

Figure 4-3. 0- to 500-volt reference power supply, block diagram.

voltage to tubes V6, V100, V104, V105, and chopper CK1.

4-3. Balanced Bridge

(figs. 4-6 and 9-5)

a. Active Tube. Input voltage is applied across low-pass filter resistor R111 and capacitor C102 to the grid of cathode follower V104A (active tube), Resistor R110 and part of potentiometer P101 are the load resistors for V104A. Applying a voltage to the grid of V104A causes the cathode voltage to change and unbalance the bridge circuit. The unbalance is proportional to the magnitude of the input voltage and is indicated on meter M1.

b. Inactive Balancing Tube. The grid of cathode follower V104B (inactive balancing tube) is connected to the - input terminal. Resistor R109 and part of potentiometer P101 are the load resistors for V104B. The cathode voltage of V104B is constant and is used as a reference in the balanced bridge circuit.

c. Meter M1. Meter M1 is a 50-microampere, zero-center, Weston type movement and is connected to indicate the difference in cathode voltages between V104A and V104B. Back-to-back diodes CR3 and CR4 conduct to shunt the meter movement if excessive voltages are developed in the bridge circuit. The diodes do not conduct during normal operation. Full-scale adjust alignment potentiometer P104 is adjusted for full-scale M1 indicator deflection with a +0.5 volt applied to the grid of V104A. The voltage across RECORDER OUTPUT GAIN ADJ potentiometer P105 is proportional to the deflection of the indicator on meter M1. This voltage is available at the + and - RECORDER OUTPUT terminals on the rear panel of the vtvm. The magnitude of this voltage is controlled by adjusting potentiometer P105, as necessary, when a recorder is in operation, Capacitor C113 acts as a low-pass filter to prevent pickup, introduced by the recorder, from affecting the accuracy of meter M1.

d. Zero-Balancing Network. VTVM-10V-1V ZERO potentiometer P101 is adjusted to balance the bridge and, therefore, zero meter M1. This adjustment compensates for differences between V104A and V104B, and is performed with no connection made to the + and -input terminals.

e. Vtvm Operation (fig. 4-6). The equipment is operated as a direct reading vtvm when the NULL switch is set to the VTVM position. The input voltage is applied to voltage divider resistors R136 through R139. Stepped down voltages are selected by VOLTS RANGE switch S8A so that 0.5 volt applied to the grid of V104A of the balanced bridge results in full-scale deflection on meter M1 for the selected range. Resistor R133, R134, or R135 is connected in series with R111 in the applicable range position to maintain a constant input resistance of approximately 11 megohms at the grid of V104A with respect to the - input terminal.

f. Differential Voltmeter Operation (fig. 9-5). The equipment is operated in the differential voltmeter mode when NULL switch S9 is placed in the 10, 1, .1, or .01 position. In this mode of operation, the voltage selected by the VOLTS RANGE switch and the voltage-divider A through E switches (para 4-4) is applied as a reference voltage to the balanced bridge and the bottom of the input voltage divider (R132, R128, and R129). The input voltage is applied to the top of the input voltage divider (R132, R128, and R129) by NULL switch S9, section C. For purposes of this discussion, assume that NULL switch S9 is in the 10 position. Voltage-divider switches A through E are then adjusted so that the reference voltage is exactly equal to the input voltage. At this point, the voltage across the R132, R128, and R129 divider is zero and, therefore, the zero voltage applied to the grid of V104A of the balanced bridge through NULL switch S9 sections E, F, and B causes a null indication. The input voltage is then read from the A through E indicators on the front panel. Resistors R129, R127, R126, and R111 maintain a constant input resistance of 11 megohms at the grid of V104A with respect to the negative side of the balanced bridge.

- (1) When NULL switch S9 is in the 1 position, the operation is the same as described in *f* above; however, S9E connection to the junction of R128 and R132 applies 10 times more of the difference between the input and reference voltages to the grid of V104A to provide greater sensitivity when reading a null. Resistors R129,

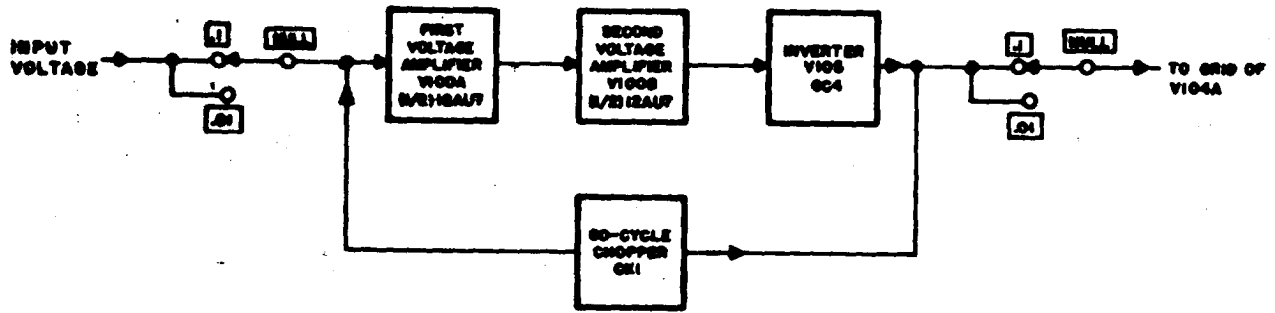

TM6625-438-60-19

Figure 4-4. 60-cycle chopper amplifier, block diagram.

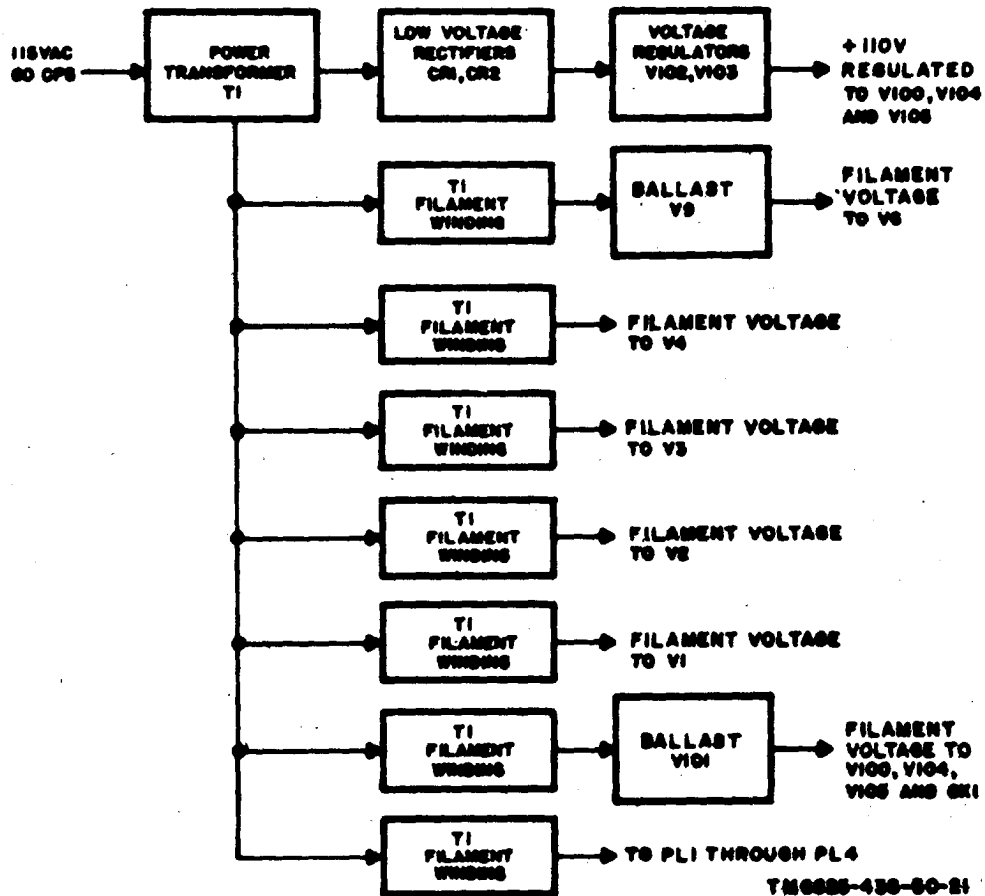

TM6625-438-60-21

Figure 4-5. Low-voltage power supply, block diagram.

R128, R126, and R111 maintain the input resistance at the grid of V104A at 11 megohms.

- (2) When NULL switch S9 is in the .1 position, section C applies the input voltage to voltage divider R130 and

4-6

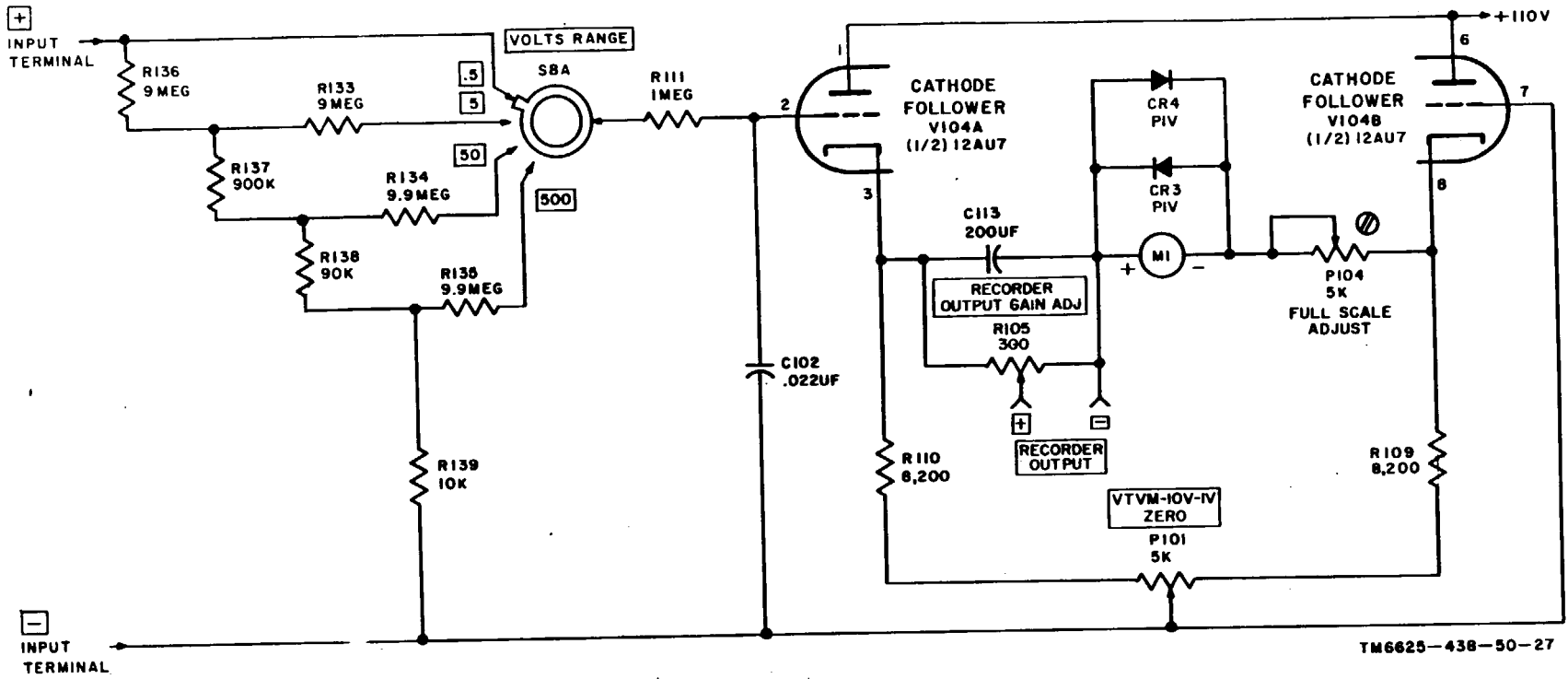

TM 11-6625-438-15

TM6625-438-50-27

Figure 4-6. Vacuum-tube voltmeter mode of operation, simplified schematic diagram.

R131, Section E selects one-tenth of the difference between the input voltage and the reference voltage, and section F applies this voltage to the chopper amplifier for a 50 times amplification (para 4-5), prior to application of the signal to the grid of V104A of the balanced bridge. The overall amplification of the difference voltage is 5 (1/10 times 50).

- (3) When NULL switch S9 is in the .01 position, section C applies the input voltage to voltage divider R130 and R131. Section E selects the full difference between the input voltage and the reference voltage, and section F applies this voltage to the chopper amplifier for a 50 times amplification prior to the application of the signal to the grid of V104A of the balanced bridge. The overall amplification of the difference voltage is 50 (1 time 50).
- (4) Note that as NULL switch S9 is rotated from the 10 to the .01 positions, the overall sensitivity of the differential voltmeter is increased so that the null reading obtained becomes more accurate.

4-4. Reference Power Supply 0- to 500-Volt (figs. 4-7, 4-8, and 9-5)

a. *Power Rectifier* (fig. 9-5). Voltage from power transformer T1 is converted to pulsating dc by full-wave rectifier tube V1. A low-pass filter is used to remove the alternating-current component of the rectified wave. In Voltmeter, Electronic AN/USM-98, serial numbers 1 through 145, the filter consists of resistor R1 and capacitors C1 and C2; on serial numbers 146 through 218, the filter consists of resistor R1 and capacitors C10, C11, and C12. Voltage-divider network, R71, R72, and R73, maintains equal voltages across capacitors C10, C11, and C12. The output of tube V1 is +900 volts unregulated.

b. *First Series Regulator* (fig. 4-7). The first series regulator consists of series regulator tube V2, control amplifier tube V3, and reference tube V5. The plate voltage for tube V2

is obtained from tube V1, and the grid voltage for tube V2 is obtained directly from the plate of tube V3. Resistor R2 is the plate load for tube V3. The screen voltage for tube V3 is obtained from voltage-divider resistors R3A through R3F and R4A and R4B. Grid voltage for tube V3 is obtained from the junction of resistor R5, capacitor C3, and resistor R6. Control amplifier tube V3 senses the difference between the output voltage at this junction point and reference tube V5, and applies a correction voltage to the grid of tube V2. When the output voltage is low (less than +625 volts), a negative correction voltage will be applied to the grid of control amplifier tube V3. This condition decreases conduction in V3 and causes the plate of V3 and the grid of series regulator tube V2 to go positive. This condition decreases the impedance of V2, which results in less voltage drop across V2, and the output, voltage increases to +625 volts. When the output voltage is high (more than +625 volts), a negative correction voltage will be applied to the grid of V2; the tube impedance increases and causes the voltage output to lower to +625 volts. The filaments of tubes V2 and V3 are operated at the same dc potentials as their cathodes. The output of the first series regulator is +625 volts regulated.

c. *Second Series Regulator* (fig. 4-8). The second series regulator consists of series regulator tube V4A, differential amplifier tube V6, control amplifier tube V4B, and reference tubes V7 and V8. The plate voltage for tube V4A is obtained from the +625-volt output of series regulator tube V2. The grid voltage for tube V4A is direct-coupled from the plate of tube V4B. The plate load for tube V4B is resistor R8. The grid voltage for tube V4B is coupled from the plate (pin 1) of tube V6 through resistor R12. Resistors R9 and R10 are plate load resistors for dual-triode tube V6. The cathode bias for both triodes of tube V6 is developed by resistor R13 and capacitor C9. Differential amplifier tube V6 develops an output voltage when a difference exists between the reference voltage obtained from tubes V7 and V8, and a sample of the output voltage coupled through R 14 from voltage-divider network R17, ADJ CAL P1, P6, and R18. Assume

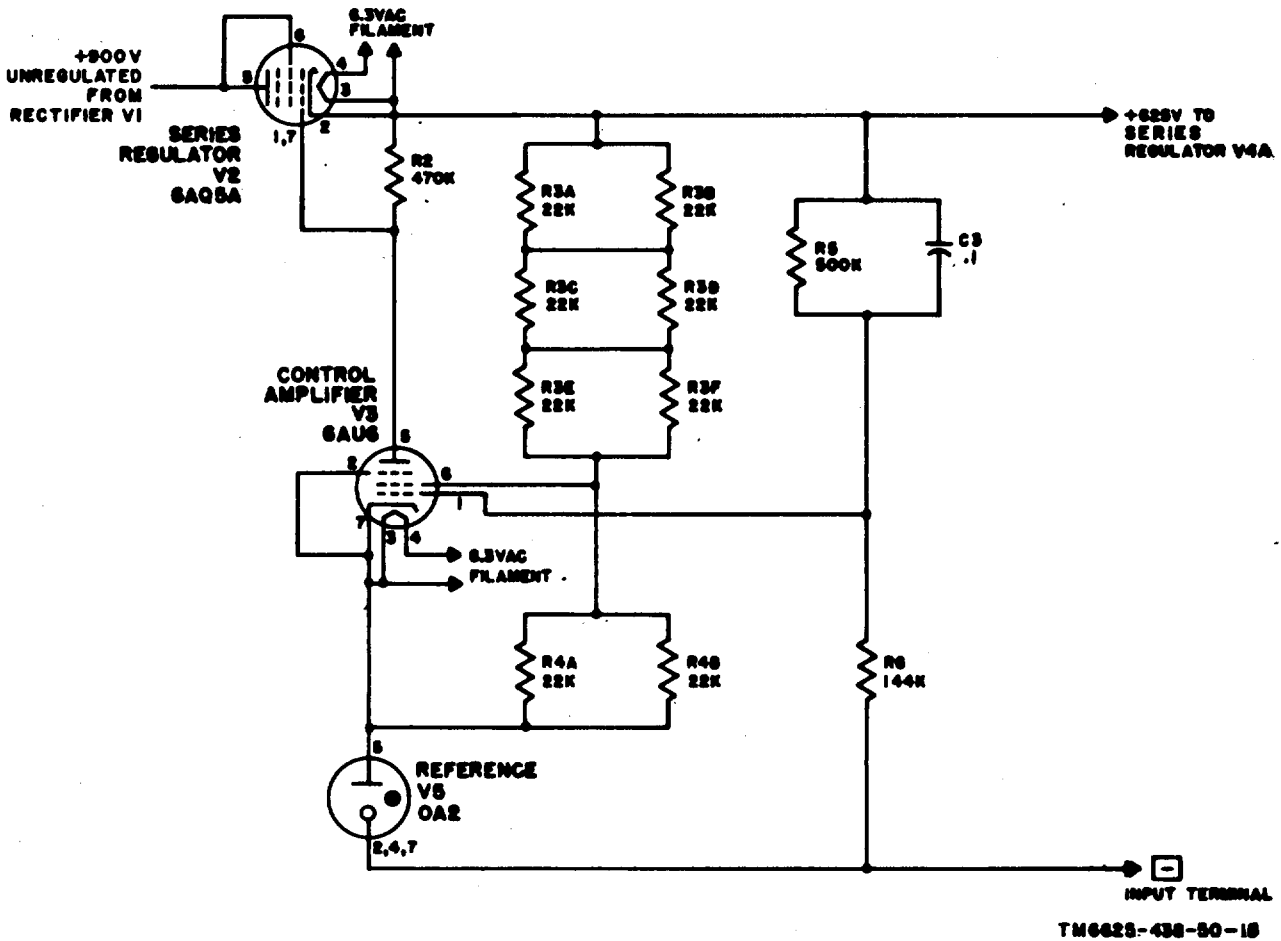

Figure .4-7. 0- to 500-volt reference power supply, first series regulator, schematic diagram.

that there is an increase in the +500-volt output, a positive-going signal applied to pin 7 (grid) of V6. This increase results in a decrease in the cathode voltage of control amplifier V4B, which causes V4B to increase conduction and drop more voltage across plate load resistor R8. The negative-going voltage on pin 2 (grid) of series regulator V4A increases the tube impedance, and more voltage is dropped across the tube to return the output voltage to +500 volts. If the +500 volts were to decrease, the impedance of series regulator V4A would be decreased in a similar manner to return the output voltage to +500 volts. Negative feedback is provided by capacitor C5 to prevent oscillation. Capacitor C6 is used to increase the response of the differential amplifier to rapid

voltage changes. ADJ CAL potentiometer P1 is adjusted to vary the output of the second series regulator. Midrange adjust potentiometer P6 is adjusted so that potentiometer P1 is in midrange when the output of the second series regulator is +500 volts. The filaments and cathodes of tubes V4 and V6 are operated at the same dc potentials. The output of the second series regulator is +500 volts regulated.

d. *Calibration Circuit* (fig. 4-8). The calibration circuit for the 500-volt reference power supply consists of calibration voltage-divider resistors R15, R19, R16, and 500-volt calibration adjust potentiometer P2, and standard cell B2. The calibration circuit is used when VOLTS RANGE switch S8 (fig. 9-5) is set to CAL, and CAL PUSH switch S7 is depressed.

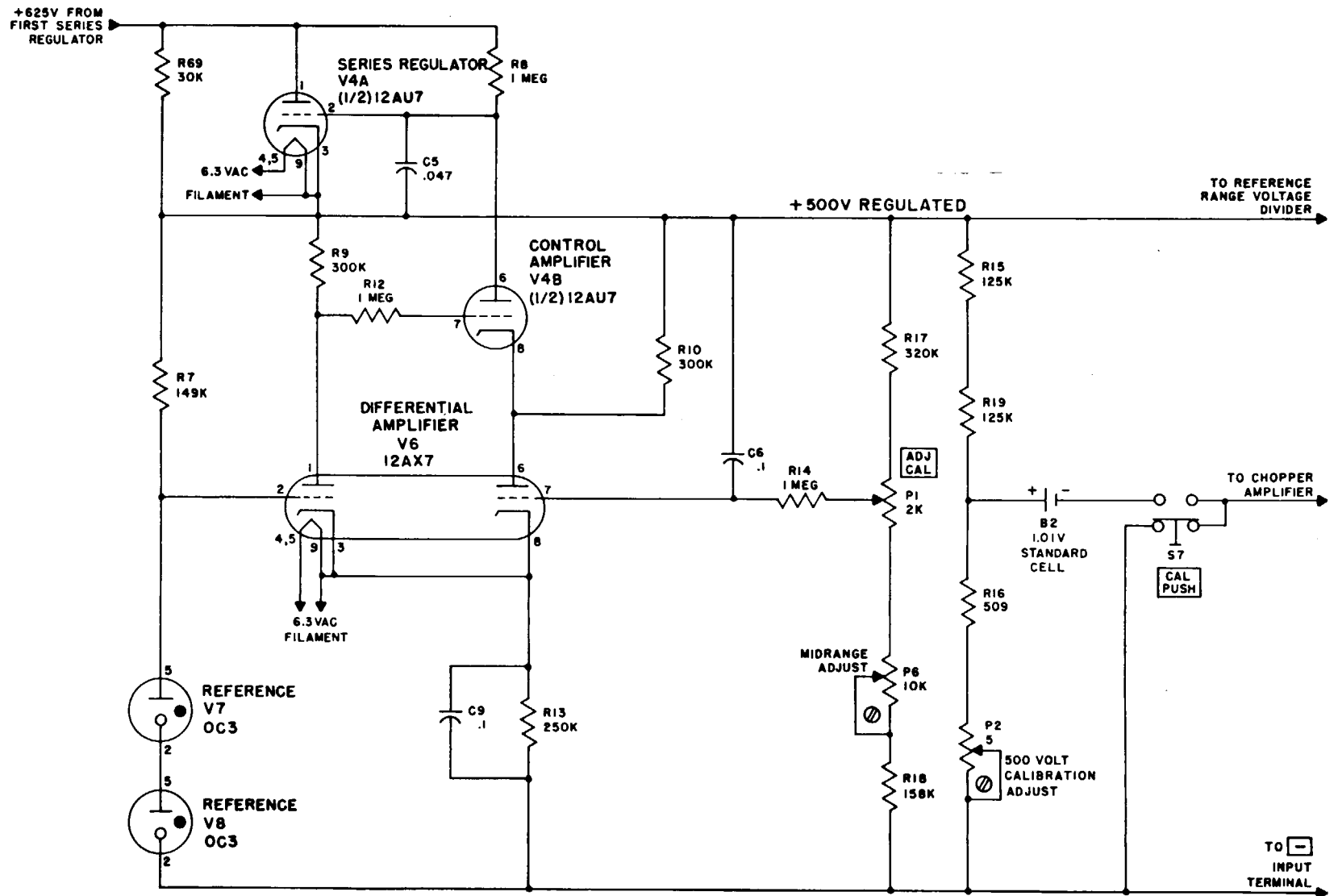

Figure 4-8. 0- to 500-volt reference power supply, second series regulator, schematic diagram.

The voltage difference between the calibration voltage-divider output and standard cell B2 is amplified by the chopper amplifier (para 4-5) and applied to the balanced bridge. An unbalanced condition in the balanced bridge circuit is indicated on meter M1. The output of the 500-volt reference power supply is then adjusted for zero meter M1 indicator deflection. Potentiometer P2 is adjusted during calibration until the difference between the calibration voltage-divider output and the standard cell is zero, and the output of the 500-volt reference power supply is exactly +500 volts..

e. Reference Voltage Divider (fig. 9-5). Separate voltage dividers are used to obtain +50-, +5-, and +0.5-volt references from the 500-volt reference power supply. The appropriate voltage divider is selected by levels G and H of VOLTS RANGE switch S8. The reference voltage dividers consist of precision wire-wound resistors R141 through R148, 50-volt calibration adjust potentiometer P3, 5-volt calibration adjust potentiometer P4, and 0.5-volt calibration adjust potentiometer P5. Potentiometers P3, P4, and P5 adjust the output level of the 50-, 5-, and 0.5-volt range dividers, respectively. Resistors R142, R143, and R141 are placed across the output of the 500-volt reference power supply when VOLTS RANGE switch S8 is set to 500 or CAL. This action maintains a load on the 500-volt reference power supply.

f. Five-Decade Attenuator (fig. 9-5). The five-decade attenuator is connected to the appropriate reference voltage divider by level H of VOLTS RANGE switch S8. The five-decade attenuator consists of voltage-divider switches S1 through S5 (A through E), respectively, associated matched, precision, wire-wound resistors R20 through R68. The positions of switches S1 through S5 are indicated by voltage-divider indicators A through E on the front panel. The resistors on voltage-divider switch S1(A) and on voltage-divider switch S2(B) are matched to be within 0.005 percent of each other. The resistors on voltage-divider switches S3, S4, and S5 (C, D, and E), respectively, are matched to be within 0.025 percent of one another. The filter, consisting of resistor R140 and capacitor C111, is connected across the output of the five-decade attenuator by level D of

VOLTS RANGE switch S8, in the 50-, 5-, and 0.5-volt ranges. This filter bypasses hash introduced by the wire-wound resistors, and provides an ac return for the chopper amplifier filter (para 4-5) to the - input terminal. Capacitor C7, located at the - input terminal, provides a return chassis ground for the hash filter. Fuse F2 protects the five-decade attenuator from overloads. Transients which are generated when switches S8 and S9 are operated, are shunted around fuse F2 by capacitor C8.

4-5. Chopper Amplifier, 60-Cycle

a. Input Circuitry (fig. 9-5). The input signal source for the 60-cycle chopper amplifier is determined by level E of VOLTS RANGE switch S8. When the VOLTS RANGE switch is set to CAL, the 60-cycle chopper amplifier input is connected to the - input terminal through CAL PUSH switch S7. When switch S7 is depressed, the 60-cycle chopper amplifier input is connected to the 500-volt reference power supply calibration circuit (para 4-4 d). When VOLTS RANGE switch S8 is set to 500, 50, 5, or .5, and NULL switch S9 is set to .1 or .01, the 60-cycle chopper amplifier input is connected to the taps on null range voltage-divider resistors R130 and R131 (para 4-3 f).

b. Amplifier Operation (fig. 9-3). The input to the 60-cycle chopper amplifier is passed through low-pass filter R123, C110, R124, and C109, and applied to the junction of R125 and C100. Terminal 6 of chopper CK1 is also applied to this junction and connects and disconnects the junction and the reference voltage at a 60-cycles per second rate; therefore, the signal at this junction is a 60-cps square wave, of which the amplitude is the difference between the input voltage and the reference voltage. The square wave is either positive or negative, depending on whether the input voltage is higher or lower than the reference voltage. This square wave is coupled through C100 to the grid of amplifier V100A as an ac square wave. Cathode bias for V100A is developed by potentiometer P103 and resistor R122. Gain adjust potentiometer P103 adjusts the gain of the 60-cycle chopper amplifier so that a 10-millivolt signal applied to the grid of tube V100A

will appear as a 0.5-volt signal at the grid of tube V104A. Resistor R120 is the plate load for V100A. The output of tube V100A is coupled to the grid of tube V100B by capacitor C107 and resistor R118. Resistor R117 is the plate load for tube V100B. The gain of the 60-cycle chopper amplifier is stabilized by a feedback network consisting of capacitor C106, resistor R119, potentiometer P103, and resistor R122. The grid bias for tubes V100A and V100B is maintained by 1.35-volt mercury cell B1. Resistor R121 is the grid bias resistor, and capacitor C12 is the grid bypass capacitor. The output of tube V100B is fed to the grid of tube V105, which inverts the square wave so that after rectification by chopper CK1 it will appear in the correct polarity at the grid of tube V104A. Resistors R114 and R115 are the plate and cathode resistors for tube V105. The output of tube V105 is coupled through capacitor C104 to the junction of resistors R113 and R112. Terminal 1 of chopper CK1 is also applied to this junction and connects and disconnects the junction and the reference voltage line at a 60-cps rate. Synchronous rectification occurs as follows:

- (1) Assume a positive difference voltage is applied to the chopper amplifier.
- (2) During the time t_1 terminal 6 of chopper CK1 is open, capacitor C100 charges and the positive portion of the ac square wave is amplified by V100A and V100B and appears at the plate of inverter V105 as a negative-going voltage. During this time, however, terminal 1 of chopper CK1 is connected to the reference voltage line and there is no output from the chopper amplifier.
- (3) During the time t_2 terminal 6 of chopper CK1 is connected to the reference voltage line, capacitor C100 discharges through R121 (the negative portion of the ac square wave), and the negative signal is amplified by V100A and V100B and appears at the plate of inverter V105 as a positive-going voltage. Since terminal 1 of chopper CK1 is open at this time, capacitor C104 charges to the higher potential at the plate of V105 through

low-pass filter R112, C103, R111, and C102, placing a positive voltage on the grid of V104A.

- (4) Similarly, when a negative-difference voltage is applied to the chopper amplifier, the timing relationship of chopper CK1 contacts 6 and 1 is such that capacitor C104 discharges through low-pass filter R112, C103, R111, and C102, placing a negative voltage on the grid of V104A.

4-6. Low-Voltage Supply

(figs. 4-9 and 9-5)

a. Input Power (fig. 4-9). The input power to the vtvmn is controlled by power switch S6. Power transformer T1 is protected by fuse F1 (2 ampere, 3AG).

b. Positive 110-Volt Supply (fig. 4-9). Positive 11.0 volts regulated for the balanced bridge and the 60-cycle chopper amplifier is obtained from a 250-volt ac secondary winding on power transformer T1. The ac voltage is half-wave rectified by rectifiers CR1 and CR2, and filtered by R101, C101A, C101B, R102A, and R102B. The de-output voltage is regulated by regulator tubes V102 and V103. Resistors R104A, R104B, R106A, and R106B are the regulating resistors for V102, and resistor R108 is the regulating resistor for V103. The negative side of the +110-volt regulated supply is connected to the positive side of the reference voltage (para 4-4).

c. Regulated Filament Supply (fig. 4-9). There are two regulated filament supplies. Each supply operates from a separate 15-volt, ac secondary winding on power transformer T1. The filament voltage for V6 is regulated by ballast tube V9. Resistor R70 provides an additional load to obtain optimum regulation by V9. The filament voltage to tubes V100, V104, and V105 and 60-cycle chopper CK1 field coil is regulated by ballast tube V101. Resistor R103 and potentiometer P102 provide an additional load to obtain optimum regulation on meter M1 when the NULL switch is set to .1 or .01. The .1V-.01V ZERO control P102 variable arm is connected to the minus side of the +110-volt regulated supply to place the filaments of V1000, V104, and V105 at

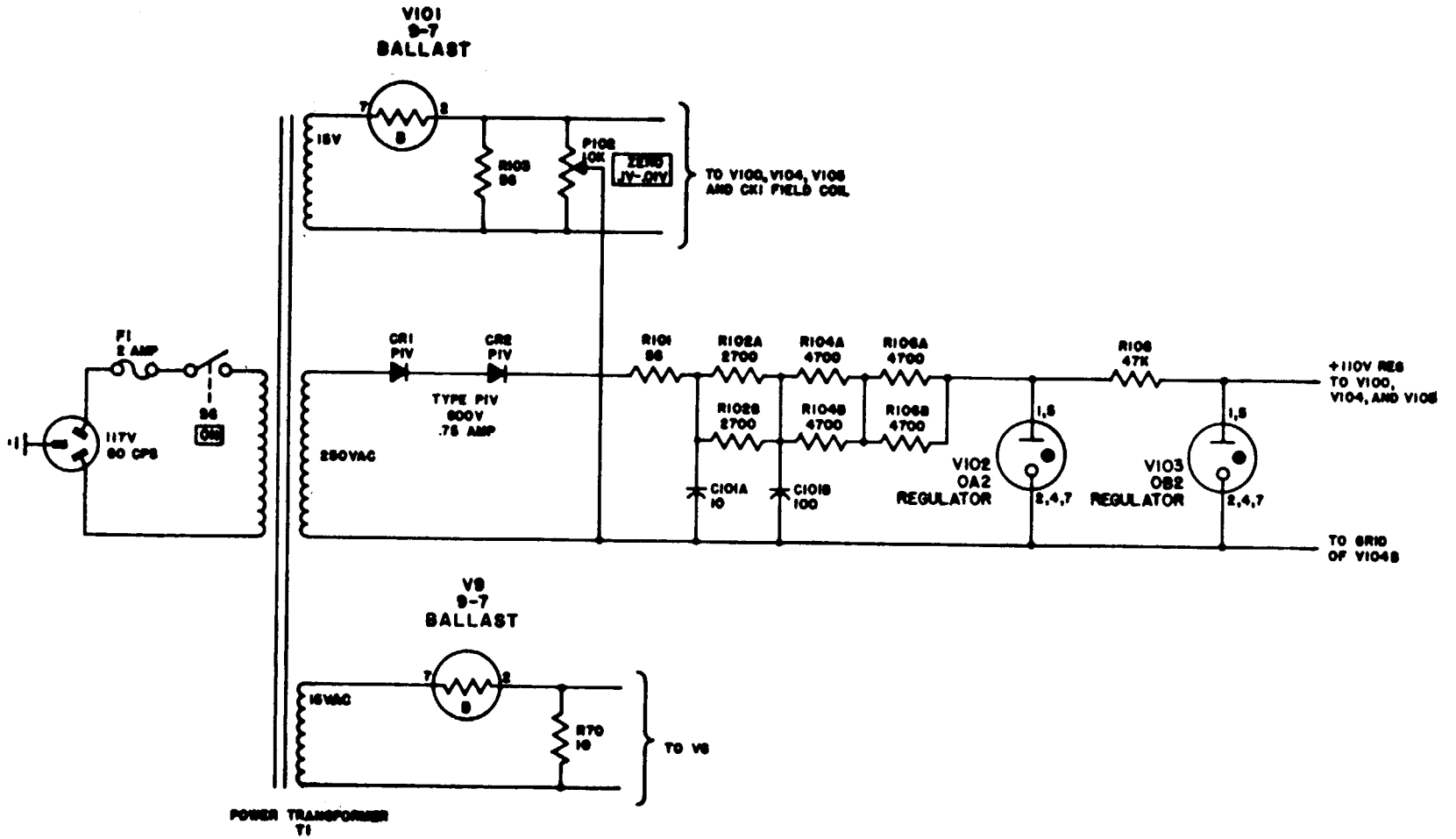

Figure 4-9. Low-voltage power supply, schematic diagram.

approximately the same dc potential as the cathodes. The control used for zeroing meter M1 is the .1 and .01 positions of NULL switch S9 to compensate for any imbalance in tubes V100 and V105.

d. Unregulated Filament Supply (fig. 9-5). The filaments of tubes V1, V2, V3, and V4, in the 500-volt reference power supply, are op-

erator at the same dc potential as their cathodes. Individual filament voltage windings on power transformer T1 are provided for each of these tubes. Decimal point indicator lamps PL1 through PL4 are energized from a 5-volt ac secondary winding on power transformer T1. The decimal point indicator lamps are selected by level B of VOLTS RANGE switch S8.

CHAPTER 5

TROUBLESHOOTING

Section I. GENERAL TROUBLESHOOTING TECHNIQUES

Warning: Be extremely careful when servicing the vtm with the case removed. Voltages in the range of 1,500 volts exist in the 500-volt reference power supply. Always disconnect the power cord and discharge the filter capacitors in the power supply before performing any servicing procedures.

5-1. General Instructions

The general support and depot maintenance procedures are not complete in themselves, but *supplement* the operational and organizational procedures described in chapter 3. The systematic troubleshooting procedure consists of localizing and isolating techniques. Paragraphs 5-4 and 5-5 contain techniques applicable to the vtm as a unit. Paragraphs 5-6 and 5-7 contain techniques applicable to isolate a defective resistor in the decade attenuator.

5-2. Organization of Troubleshooting Procedures

a. General. The first step in servicing a defective vtm is to localize the fault. Localization means tracing the fault to the circuit responsible for the abnormal operation of the equipment. The second step is to isolate the fault. Isolation means tracing the fault to a defective part responsible for the abnormal condition. Some faults, such as burnt-out resistors and arcing or shorted transformers, can often be located by sight, smell, or hearing. The majority of faults, however, must be localized by checking the voltages and the resistances.

b. Localization. The vtm can be divided into four circuits: the balanced bridge, the 0- to 500-volt reference power supply, the 60-cycle chopper amplifier, and the low-voltage supply. The first step in tracing the trouble is to locate the circuit at fault by the following methods:

- (1) *Visual inspection.* The purpose of visual inspection is to locate faults without the testing or measuring of cir-

cuits. All meter readings or other visual signs should be observed and an attempt made to localize the fault to a particular circuit.

- (2) *Operational tests.* Operational tests frequently indicate the general location of trouble. In many instances, the tests will help in determining the exact nature of the fault. The troubleshooting chart given in paragraph 3-11 is an operational test.

c. Isolation. After the trouble has been localized, the next step is to locate the specific component, or components responsible for the improper operation. The tests listed below will aid in isolating the trouble.

Caution: Remove the plug to standard cell B2 before taking voltage and resistance measurements to prevent accidental shorting and resulting damage.

- (1) *Voltage and resistance measurements.* Use the resistor and the capacitor color codes (figs. 9-1 and 9-2) or the overall schematic diagram (fig. 9-5) to determine component values. Use the voltage and resistance diagram (fig. 9-4) to find normal readings, and compare them with readings taken. The dc resistances of the power transformer windings are listed in figure 5-1.
- (2) *Troubleshooting chart.* The symptoms listed in the troubleshooting chart (para 5-5) will aid in isolating the trouble to a component part. Use

figures 5-2 through 5-8 for component locations.

(3) *Intermittent troubles.* The possibility of intermittent troubles should not be overlooked in any test. Intermittent troubles can often be made to appear by gently tapping or jarring the

equipment. Check the wiring and the connections within the vtvm.

5-3. Test Equipment Required

The following chart lists the test equipment required for troubleshooting the vtvm. Also listed are the associated manuals and the common names.

Test equipment	Technical manual	Common name
Test Set, Electron Tube TV-7(*)/U ¹ .	TM 11-6625-274-12	Tube tester.
Multimeter TS-352B/U _____	TM 11-6625-36&15	Multimeter.
Voltmeter, Digital AN/G SM-64 ___	TM 11-6625-444-15	Digital voltmeter.
John Fluke Model 406D Power Supply, or equal.	-----	Power supply.

¹Represents Test Sets, Electron Tube TV-7/U, TV-7A/U, TV-7B/U, and TV-7D/U.

AG NOMINAL VOLTAGE	WINDING COLOR	RESISTANCE (OHMS)	REMARKS
115	WHT-WHT	4.08	PRIMARY
250	BLK-BLU	160	+110 VOLT SUPPLY.
15	BLU-BRN/WHT	9.6	FILAMENT VOLTAGE TO V6. GREEN TAP NOT USED.
6.3	GRY-GRY	.135	FILAMENT VOLTAGE TO V4.
6.3	VIO-VIO	.135	FILAMENT VOLTAGE TO V3.
6.3	ORN-ORN	.5	FILAMENT VOLTAGE TO V2.
5	YEL-YEL	.3	FILAMENT VOLTAGE TO V1.
1800	RED-RED	680	800 VOLT REFERENCE SUPPLY
15	WHT-BRN	.7	FILAMENT VOLTAGE TO V103, V104, V105 AND CK1. YELLOW NOT USED.
5	BLU-BRN	.27	FILAMENT VOLTAGE TO PL1 THROUGH PL4

Figure 5-1. Power transformer T1, voltage and resistance diagram.

Section II. TROUBLESHOOTING VOLTMETER, ELECTRONIC AN/USM-98

5-4. Troubleshooting Sequence

Troubleshooting of the vtvm is accomplished with the use of the schematic diagram (fig. 9-5), the voltage and resistance measurements (figs. 5-1 and 9-4), and the troubleshooting chart (para 5-5). Parts locations are indicated in figures 5-2 through 5-8. Many troubles in the vtvm can be quickly isolated by scanning the list of symptoms given in the troubleshooting chart. If a corresponding symptom cannot be found, or if no operational symptoms are known, perform the alignment preparation and test procedures (paras 6-8 and 6-9).

5-5. Troubleshooting Chart

The troubleshooting chart lists the probable causes corresponding to malfunction symptoms obtained during operational checks. Voltage and resistance measurements should be used to supplement the troubleshooting chart and isolate the trouble to a particular part.

Caution: If the vtvm is tilted more than 45°, it must be set in the normal, upright position for a period of 48 hours before the vtvm will regain its calibrated accuracy.

Item No.	Trouble symptom	Probable trouble	Corrective measures
1	Decimal point indicator lamp does not light when power switch is set to ON.	No ac power is applied to vtvm -	Check fuse F1; replace as necessary. If replaced fuse burns out, check filter capacitors and T1 (figs. 5-4 and 5-6) and replace as necessary.
2	No buzzing from 60-cycle chopper CK1.	a. No voltage to CK1 ----- b. Faulty CK1 -----	a. Check for nominal 6.3 volts ac between pins 3 and 4 of CK1 (fig. 5-5). b. Replace CK1 (para 6-4).
3	Meter M1 indicator will not zero by adjusting the VTVM-10V-1V ZERO control.	a. Faulty cathode follower V104. b. Faulty component ----- c. Faulty switches S8 and S9 -----	a. Check V104; replace as necessary. Refer to paragraphs 6-3 and 6-6. b. Check components in the balanced bridge circuit (figs. 6-5 and 9-4). Replace faulty component as necessary. c. Check switches S8 and S9 (fig. 5-8); replace as necessary.
4	Meter M1 indicator does not return to ZERO when the NULL switch is set to 10 and 1, or to .1 and .01.	a. Faulty V104 ----- b. Faulty V100 or V105 ----- c. Faulty mercury cell B1 ----- d. Faulty switches S8 or S9 ----- e. Faulty component -----	a. Check V104; replace as necessary. Refer to paragraphs 6-8 and 6-8. b. Check V100 and V105 (para 6-3); replace as necessary. c. Check and replace B1 if voltage is below 1.2 volts (fig. 5-5). (The normal service life of B1 is 2 to 4 years.) d. Check switches S8 and S9; replace as necessary. e. Check components in the 60-cycle chopper amplifier and balanced bridge circuits (figs. 6-6 and 9-3). Replace faulty components as necessary.

Item No.	Trouble symptom	Probable trouble	Corrective measures
5	ADJ CAL control cannot adjust for a zero deflection of meter M1 indicator.	<p>a. Faulty 500-volt reference power supply.</p> <p>b. Potentiometer P2 or P6 out of adjustment.</p> <p>c. Faulty standard cell B2 -----</p>	<p>a. Check V1, V2, V3, V4, V5, V6, V7, and V8. Check components in the 500-volt reference power supply (fig. 5-7). Replace tube or components as necessary. Refer to paragraphs 6-3 and 6-5.</p> <p>b. Perform alignment test procedure given in paragraph 6-9.</p> <p>Caution: Use only a null type meter to measure B2.</p> <p>c. Check and replace B2 if voltage is below 1.019 volts. (The normal service life of B2 is 8 to 15 years.)</p>
6	Excessive drift in 500-volt reference power supply; vtvm must be recalibrated every 5 or 10 minutes due to meter M1 indicator drift.	<p>a. Defective reference tube V7 or V8.</p> <p>b. Leaky capacitor C6 -----</p> <p>c. Faulty differential amplifier V6.</p>	<p>a. Check V7 and V8 (para 6-3); replace as necessary.</p> <p>b. Check C6; replace if faulty.</p> <p>c. Check V6 (paras 6-3 and 6-5); replace as necessary.</p>
7	Meter M1 indicator rattles when NULL switch is set to 10 and 1.	<p>a. Faulty standard cell B2 -----</p> <p>b. Defective reference tube V7 or V8.</p> <p>c. Faulty hash filter -----</p>	<p>a. Refer to step 5.</p> <p>b. Check V7 and V8 (para 6-3); replace as necessary.</p> <p>c. Check R140 and C111; replace faulty component.</p>
8	Meter M1 indicator rattles when NULL switch is set to .1 and .01.	<p>a. Faulty V100 -----</p> <p>b. Faulty tube V102 or V103 ----</p> <p>c. Faulty filter component -----</p>	<p>a. Check V100 (para 6-3); replace if faulty.</p> <p>b. Check V102 and V103 (para 6-3); replace as necessary.</p> <p>c. Check C101, R102, R104, and R106; replace as necessary.</p>
9	No filament voltage to V100, V104, V105, or CK1.	Defective ballast V101 -----	Check V101 (para 6-3); replace if defective.
10	No filament voltage to V6.	Defective ballast V9 -----	Check V9 (para 6-3); replace if defective.
11	Potentiometer P104 cannot be adjusted for full-scale deflection of meter M1 indicator during calibration.	<p>a. Faulty cathode follower V104 --</p> <p>b. Faulty component -----</p>	<p>a. Check V104; replace as necessary. Refer to paragraphs 6-3 and 6-6.</p> <p>b. Check components in the balanced bridge circuits (figs. 5-5 and 9-5). Replace faulty component as necessary.</p>
12	Meter M1 does not indicate within tolerance when used as a vacuum-tube voltmeter.	Faulty component -----	Check R133 through R139; replace faulty component.
13	The 50-volt adjust potentiometer, P3, cannot be adjusted for a null indication on meter M1 during calibration.	Faulty component -----	Check R142, R143, R144, and P3; replace faulty component.

Item No.	Trouble symptom	Probable trouble	Corrective measures
14	The 5-volt adjust potentiometer, P4, cannot be adjusted for a null indication on meter M1 during calibration.	Faulty component -----	Check R147, P4, and R145; replace faulty component.
15	The 0.5-volt adjust potentiometer, P5, cannot be adjusted for a null indication on meter M1 during calibration.	Faulty component -----	Check R148, P5, and R146; replace faulty component.
16	Meter M1 does not indicate full scale when NULL switch is set to 10 or 1 during adjustment.	Faulty component -----	Check R126 through R129 and R132; replace faulty component.
17	The gain adjust potentiometer, P103, cannot be adjusted for full-scale meter deflection of indicator on meter M1 during adjustment.	<p>a. Faulty amplifier V100 or inverter V105.</p> <p>b. Faulty component -----</p> <p>c. Faulty chopper CK1 -----</p>	<p>a. Check V100 and V105 (para 6-3); replace if faulty.</p> <p>b. Check components in the 60-cycle chopper amplifier circuits (fig. 5-5) Replace faulty component as necessary.</p> <p>c. Replace chopper CK1 if defective.</p>
18	Meter M1 does not read full scale when NULL switch is set to .1 or .01 during adjustment.	Faulty component -----	Check R130 and R131; replace faulty component.
19	With VOLTS RANGE switch set to 500, NULL switch set to 1, and voltage-divider switches A through E set to 4, 0, 0, 0, 0, respectively, meter M1 indicator deflects more than 10 percent to the left.	Dust and foreign matter causing leakage resistance.	Clean vtvm in accordance with instructions given in paragraph 6-7.

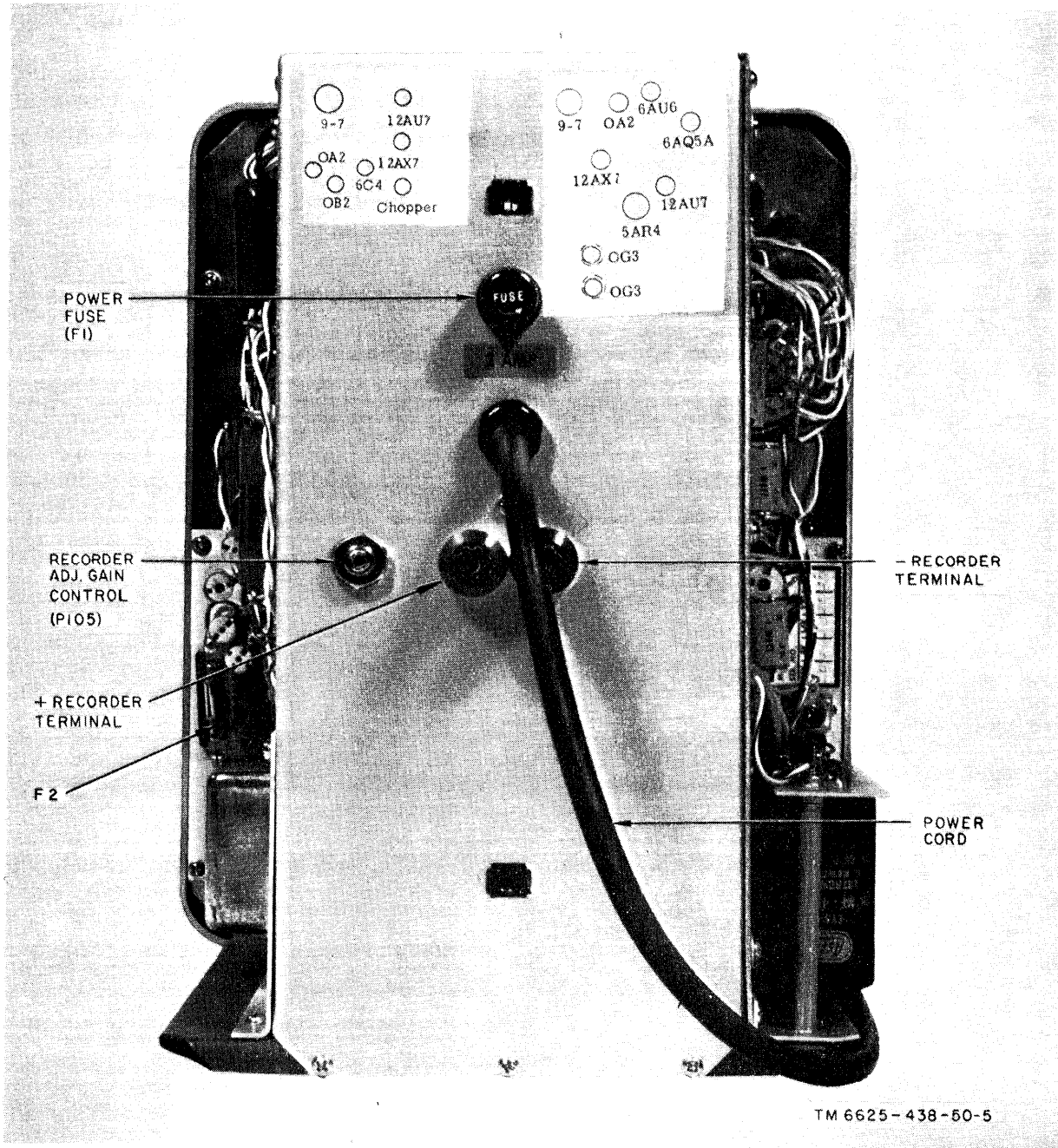

Figure 5-2. Voltmeter, Electronic AN/USM-98, component location, rear view.

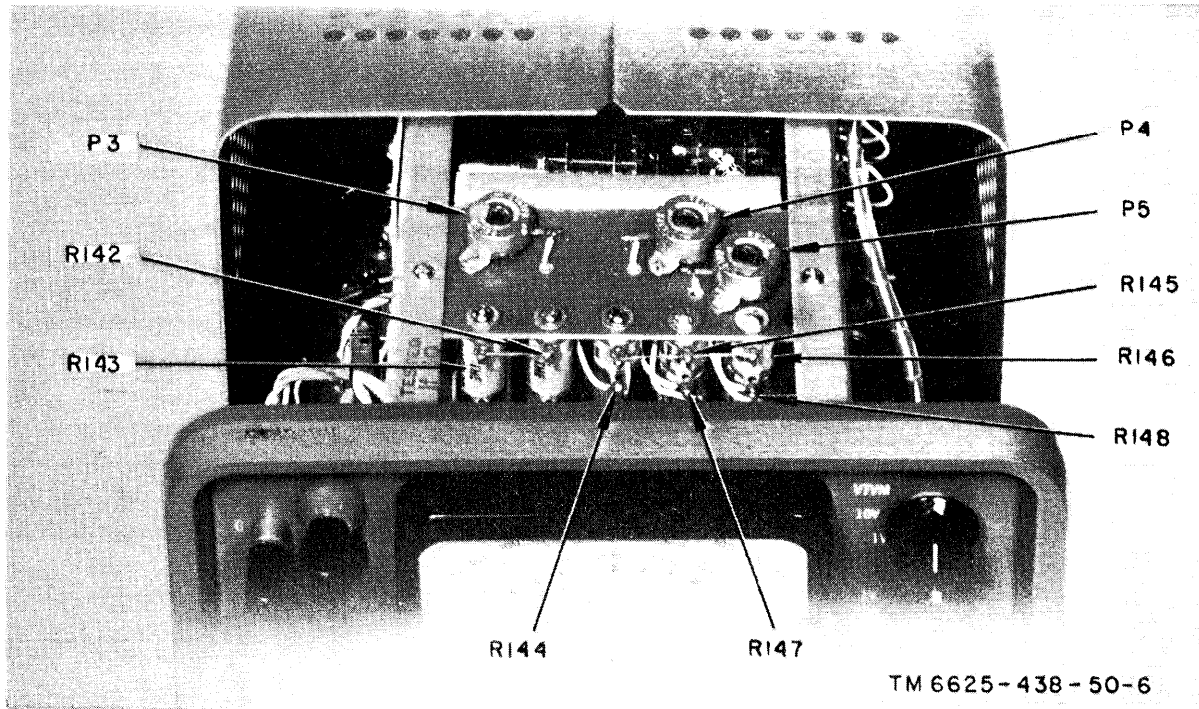

Figure 5-3. Voltmeter, Electronic AN/ USM-98, component location, top view.

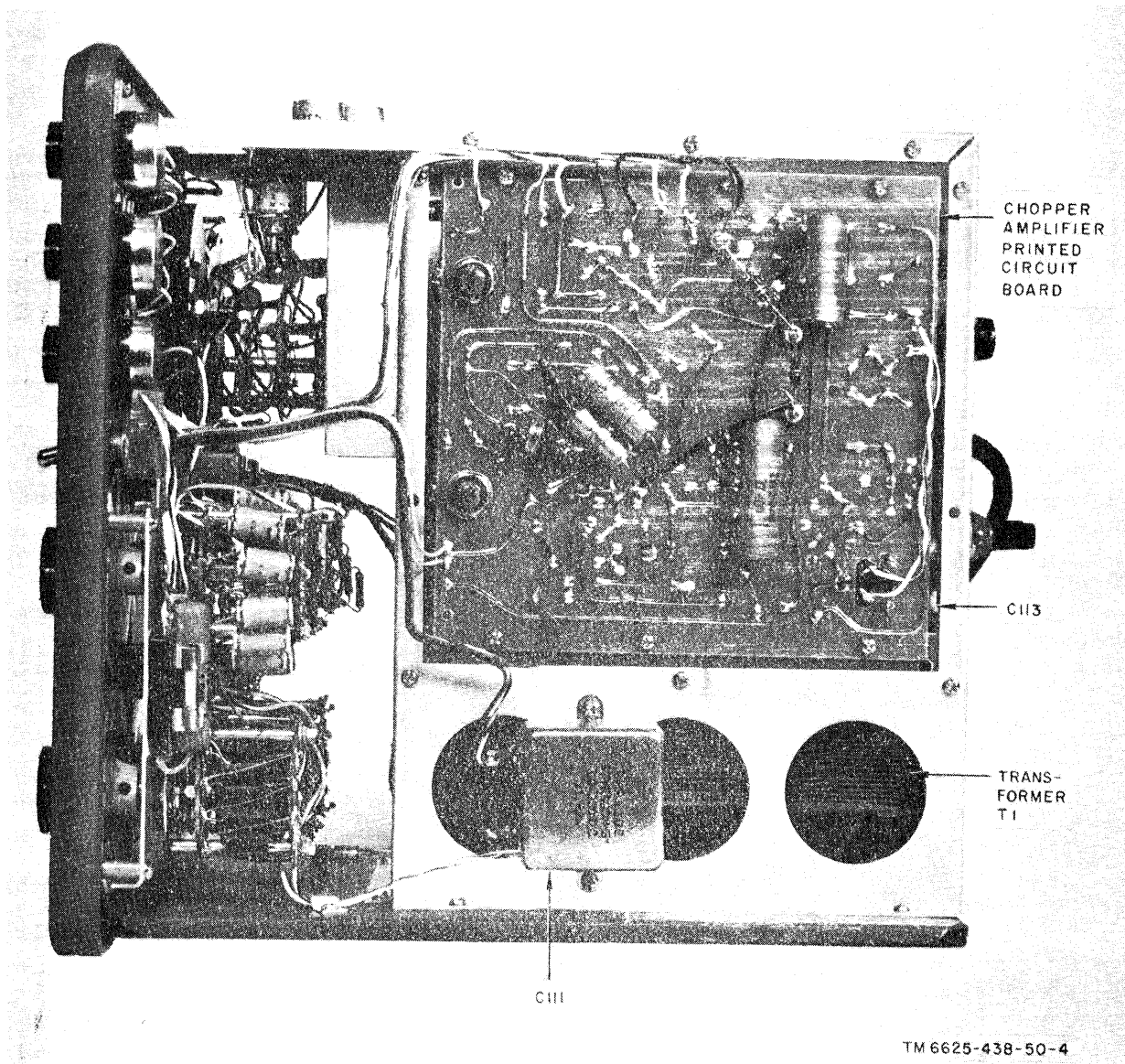
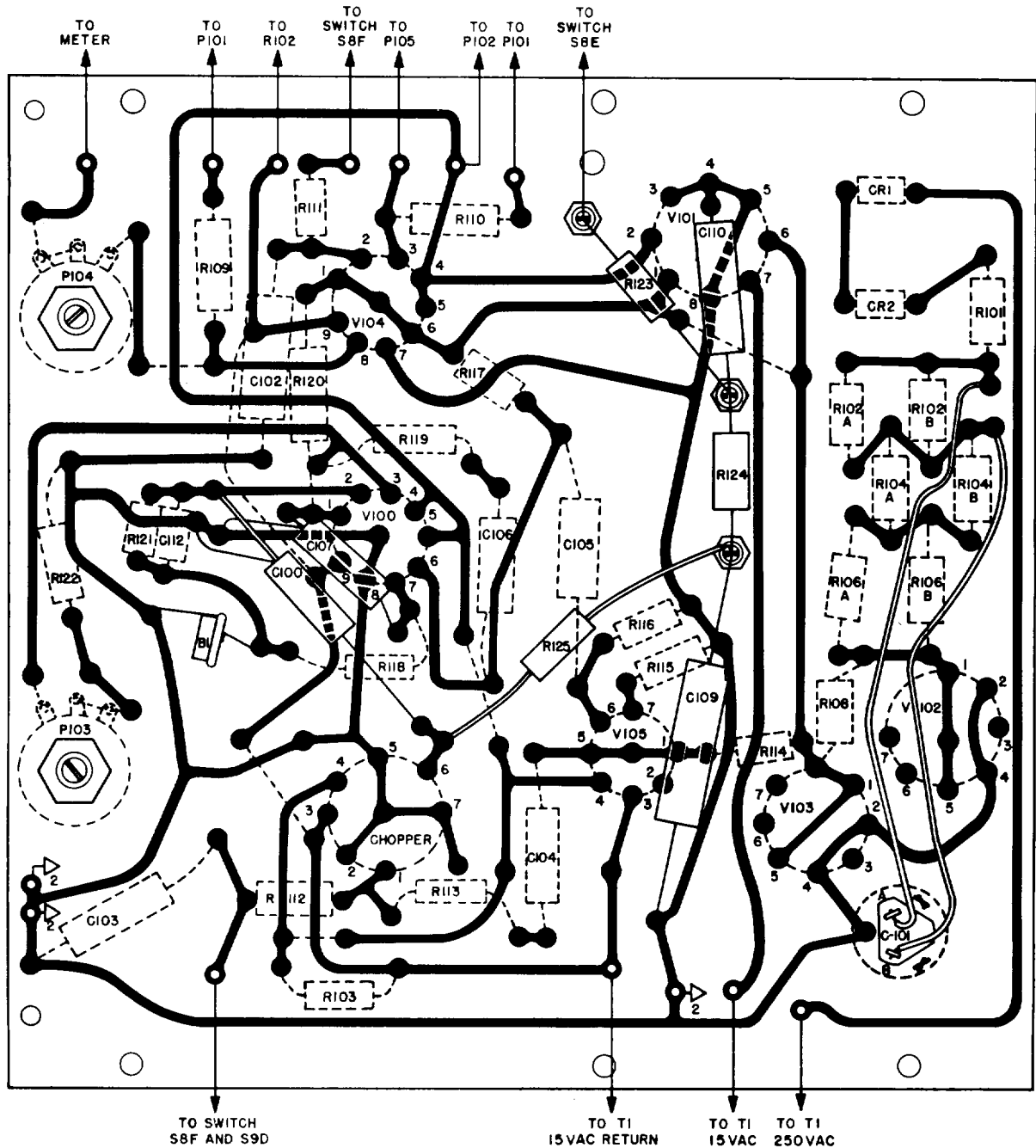

Figure 5-4. Voltmeter, Electronic AN/USM-98, component location, left side view.



- NOTES:
1. CIRCUIT VIEWED FROM SIDE ON WHICH PRINTED WIRING APPEARS.
 2. — PARTS AND PIGTAILS ON FRONT OF BOARD.
 3. - - - PARTS AND PIGTAILS ON BACK OF BOARD.
 4. — WIRING ON FRONT OF BOARD.
 5. ■ ■ ■ WIRING ON FRONT OF BOARD BUT UNDER A PART.
 6. ↖₂ DENOTES LOW VOLTAGE POWER SUPPLY COMMON TERMINAL.

Figure 5-5. Chopper amplifier printed circuit board.

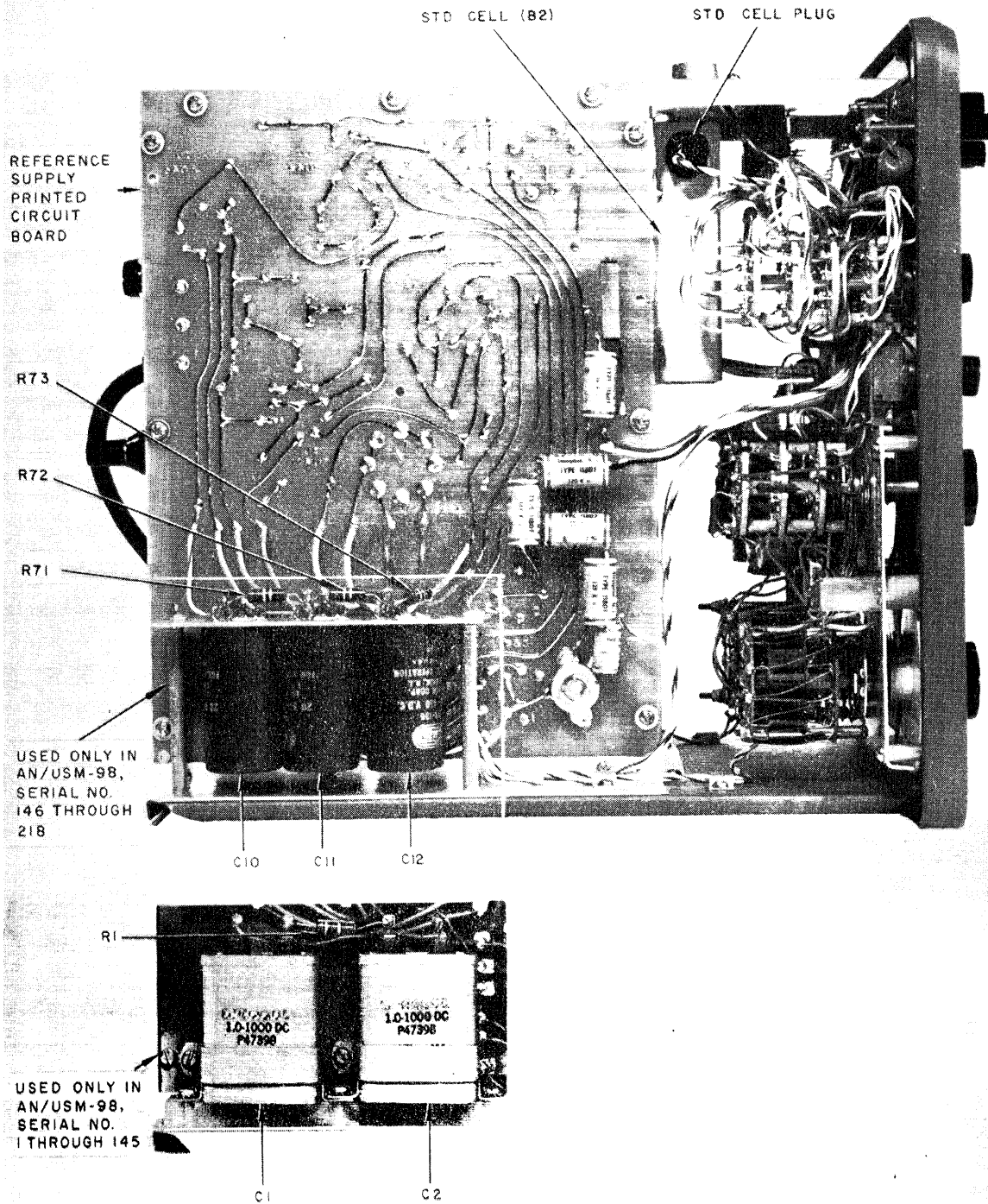

Figure 5-6. Voltmeter, Electronic AN/USM-98, component location, right side view.

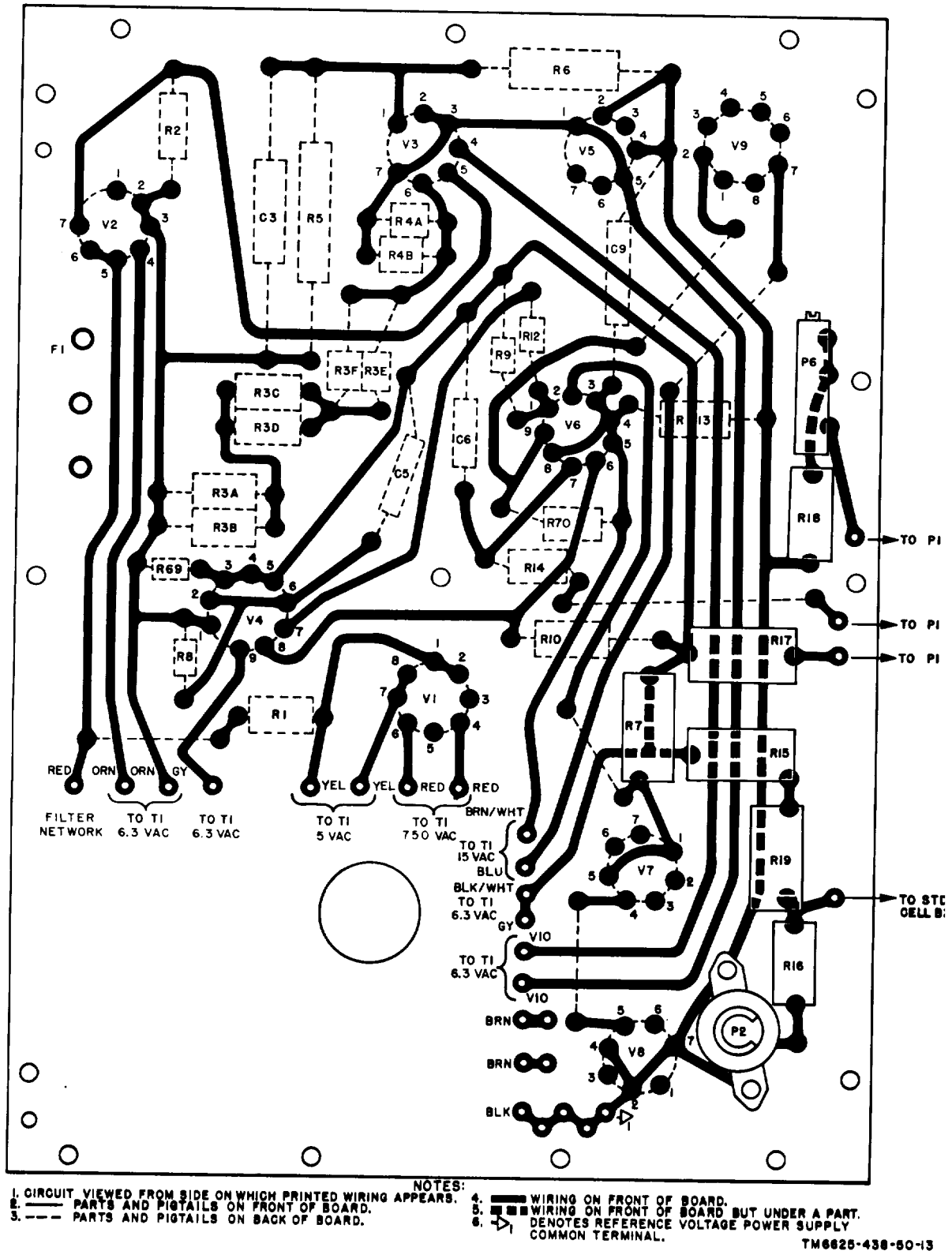

Figure 5-7. Reference supply printed circuit board.

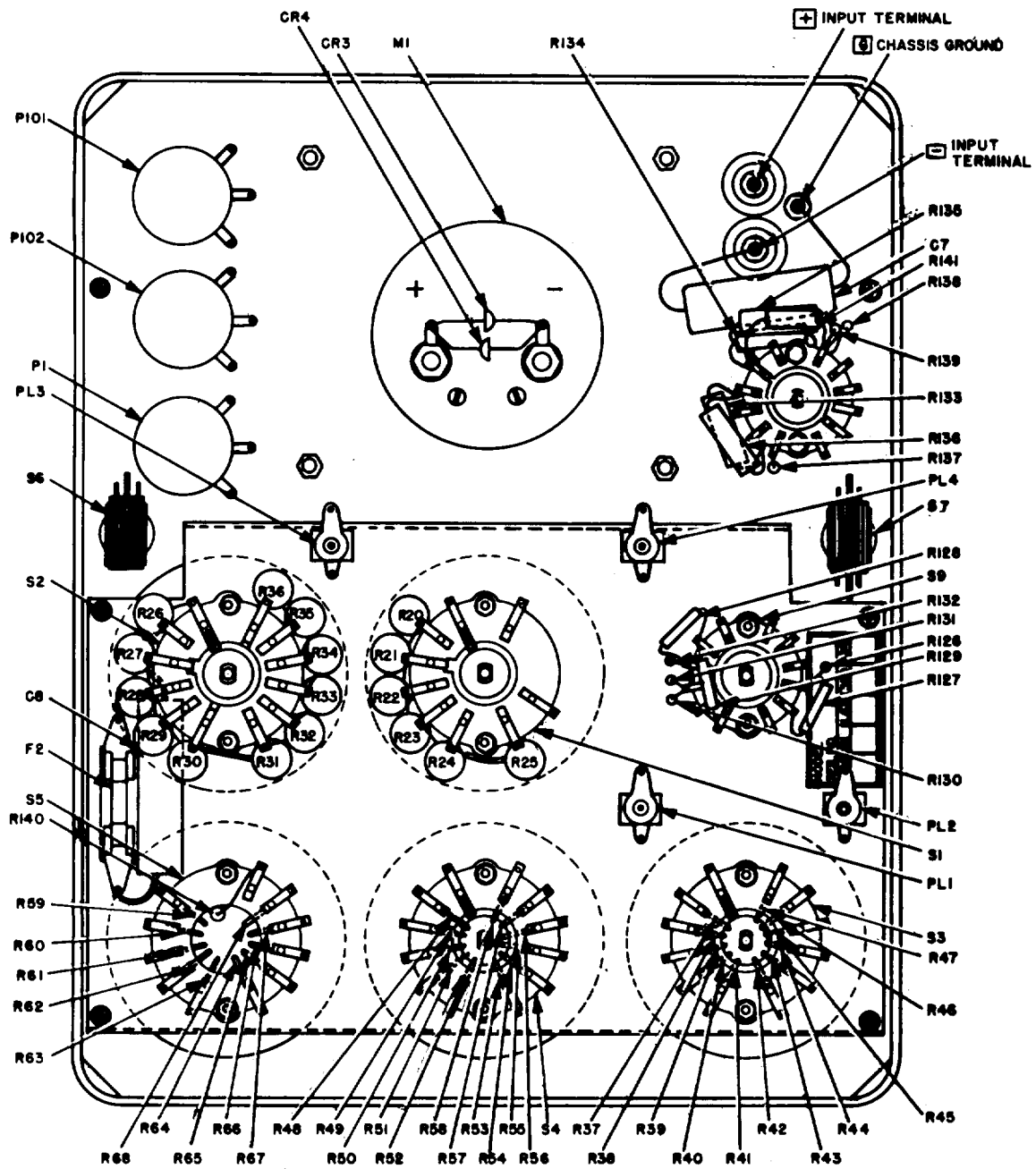

Figure 5-8. Voltmeter, Electronic AN/USM-98, component location, front panel rear view.

Section III. DECADE RESISTOR FAULT ISOLATION

5-6. Fault Indication

The resistors used in voltage-divider switches A through E decades are considered to be faulty when measurements are in error in ex-

cess of specified tolerance values (para 1-5) or when the criteria in the test given in paragraph 5-7 are exceeded. Fault isolation within each decade consists of checking each position

cm the voltage-divider switches (S1-S5) for linearity or equal changes.

5-7. Fault Test Procedure

Caution: If the vtvm is tilted more than 45°, it must be set in the normal, upright position for a period of 48 hours before the vtvm will regain its calibrated accuracy.

a. Preparation.

- (1) Place the equipment in a clean, draft-free room.
- (2) Set the front panel controls as follows:
 - (a) VOLTS RANGE switch to 500.
 - (b) NULL switch to VTVM.
 - (c) Voltage-divider switches A through E to 0.
 - (d) Power switch to ON.
- (3) Turn on the power supply and allow 1 hour for the power supply and the vtvm to stabilize.
- (4) Adjust the VTVM-10V-1V ZERO control to zero the indicator on VOLTS meter M1.
- (5) Turn the NULL switch to .1.
- (6) Adjust the 1V-.01V ZERO control to zero the indicator on VOLTS meter M1.
- (7) Turn the VOLTS RANGE switch to CAL.
- (8) Depress the CAL PUSH switch, and vary the ADJ CAL control to zero the indicator on volts meter M1.
- (9) Set up the ratio set to deliver a 50-volt output when 50 volts are applied to the input of the ratio set.

- (10) Set the front panel controls as follows;
 - (a) NULL switch to VTVM.
 - (b) VOLTS RANGE switch to 50.
 - (c) Voltage-divider switch A to 4.
 - (d) Voltage-divider switches B C, and D to 9.
 - (e) Voltage-divider switch E to 10,
- (11) Connect the equipment as shown in figure 5-9.
- (12) Adjust the power supply until the vtvm indicates +50 volts.
- (13) Turn the NULL switch to 10, 1, .1, and .01. Refine the adjustment of the power supply for a zero indication on VOLTS meter M1 in each successive position of the NULL switch.

b. Voltage-Divider Switch A Check.

- (1) Set the front panel controls as follows:
 - (a) Null switch to VTVM.
 - (b) VOLTS RANGE switch to 50.

Caution: Always set the NULL switch to VTVM before changing the setting of the ratio set or voltage-divider switch A.

- (2) Perform steps 1 through 4 indicated in the following chart to determine a defective resistor in the voltage-divider switch A decade. NULL indications beyond the specified tolerance (0.05 percent) indicate an out-of-tolerance resistor in the A decade (resistors R20 through R25).

Step	Voltage-divider switches B through E setting	Ratio set output (volts)	Voltage-divider switch A setting	NULL switch setting	VOLTS meter M1 tolerance (volt)
1	0	10	1	1	± 0.005
2	0	20	2	1	± 0.01
3	0	30	3	1	± 0.015
4	0	40	4	1	± 0.02

- (3) Turn the NULL switch to VTVM.

c. Voltage-Divider Switch B Check.

Caution: Always set the NULL switch to VTVM before changing the setting of the ratio set or voltage-divider switch B.

- (1) Perform steps 1 through 9 indicated

in the following chart to determine a defective resistor in the voltage-divider switch B decade, Null indications beyond the specified tolerance (0.05 percent) indicate an out-of-tolerance resistor in the B decade (resistors R26 through R36).

Step	Voltage-divider switches A and C through E Setting	Ratio set output (volts)	Voltage-divider switch B setting	NULL switch setting	VOLTS meter M1 null tolerance (volt)
1	0	1	1	.1	± 0.0005
2	0	2	2	.1	± 0.001
3	0	3	3	.1	± 0.0015
4	0	4	4	.1	± 0.002
5	0	5	5	.1	± 0.0025
6	0	6	6	1	± 0.003
7	0	7	7	1	± 0.0035
8	0	8	8	1	± 0.004
9	0	9	9	1	± 0.0045

(2) Turn the NULL switch to VTVM.

d. Voltage-Divider Switch C Check.

Caution: Always set the NULL switch to VTVM before changing the setting of the ratio set or voltage-divider switch C.

(1) Perform steps 1 through 9 indicated

in the following chart to determine a defective resistor in the voltage-divider switch C decade. Null indications beyond the specified tolerance (0.05 percent) indicate an out-of-tolerance resistor in the C decade (resistors R37 through R47).

Step	Voltage-divider switches A, B, D, and E setting	Ratio set output (volt)	Voltage-divider switch C setting	NULL switch setting	VOLTS meter M1 null tolerance (volt)
1	0	0.1	1	.01	± 0.00005
2	0	0.2	2	.01	± 0.0001
3	0	0.3	3	.01	± 0.00015
4	0	0.4	4	.01	± 0.0002
5	0	0.5	5	.01	± 0.00025
6	0	0.6	6	.1	± 0.0003
7	0	0.7	7	.1	± 0.00035
8	0	0.8	8	.1	± 0.0004
9	0	0.9	9	.1	± 0.00045

(2) Turn the NULL switch to VTVM.

e. Voltage-Divider Switch D Check.

Caution: Always set the NULL switch to VTVM before changing the setting of the ratio set or voltage-divider switch D.

(1) Perform steps 1 through 9 indicated

in the following chart to determine a defective resistor in the voltage-divider switch D decade. Null indications beyond the specified tolerance (0.05 percent) indicate an out-of-tolerance resistor in the D decade (resistors R48 through R58).

Step	Voltage-Divider switches A, B, C and E setting.	Ratio set output (volt)	Voltage-divider switch D setting	NULL switch setting	VOLTS meter M1 null tolerance (volt)
1	0	0.01	1	.01	± 0.00005
2	0	0.02	2	.01	± 0.00005
3	0	0.03	3	.01	± 0.00005
4	0	0.04	4	.01	± 0.00005
5	0	0.05	5	.01	± 0.00005
6	0	0.06	6	.01	± 0.00006
7	0	0.07	7	.01	± 0.00007
8	0	0.08	8	.01	± 0.00008
9	0	0.09	9	.01	± 0.00009

(2) Turn the NULL switch to VTVM.
 f. *Voltage-Divider Switch E Check.*

Caution: Always set the NULL switch to VTVM before changing the setting of the ratio set or voltage-divider switch E.

(1) Perform steps 1 through 9 indicated

in the following chart to determine a defective resistor in the voltage-divider switch E decade. Null indications beyond the specified tolerance (0.05 percent) indicate an out-of-tolerance resistor in the E decade (resistors R59 through R67).

Step	Voltage-divider switch A through D setting	Ratio Set output (volt)	Voltage-divider switch E setting	NULL switch setting	VOLTS meter M1 null tolerance (volt)
1	0	0.001	1	.01	± 0.00005
2	0	0.002	2	.01	± 0.00005
3	0	0.003	3	.01	± 0.00005
4	0	0.004	4	.01	± 0.00005
5	0	0.005	5	.01	± 0.00005
6	0	0.006	6	.01	± 0.00005
7	0	0.007	7	.01	± 0.00005
8	0	0.008	8	.01	± 0.00005
9	0	0.009	9	.01	± 0.00005

(2) Turn the NULL switch to VTVM.

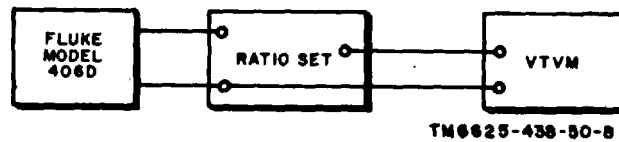

Figure 5-9. Decade resistor fault isolation, test setup.

CHAPTER 6

REPAIRS AND ALIGNMENT

Section I. REPAIRS

6-1. General Parts Replacement Techniques

All the parts of Voltmeter, Electronic AN/USM-98 can be reached and replaced without special procedures. Do not attempt to replace any of the precision wire-wound resistors with ordinary power resistors, Nichrome resistors, carbon or deposited carbon resistors, or metal film resistors. Use only approved components when making the repairs. The vtvm should be readjusted after any of the components are replaced. The selection of the tubes used as V6

in the 500-volt reference power supply, and V104 in the balanced bridge circuit is critical. A method to select these tubes is described in paragraphs 6-5 and 6-6.

6-2. Test Equipment Required

The following chart lists test equipment required for repair and alignment of the vtvm. It also lists the associated manuals, and the common names.

Test equipment	Technical manual	Common name
John Fluke Model 406D Power Supply, or equal.	-----	Power supply.
Voltmeter, Digital AN/GSM-64 -- Dc Ratio Standard, Gertsh Model 1001, or equal.	TM 11-6625-444-15 -----	Digital voltmeter. Ratio set.
Variable Transformer CN-16A/U.	-----	Variable transformer.
Test Set, Electron Tube TV-7(*)/U.	TM 11-6625-274-12	Tube tester.
Multimeter TS-352B/U -----	TM 11-6625-366-15	Multi meter.

*Represents Test Sets, Electron Tube TV-7/U, TV-7A/U, TV-7B/U, and TV-7D/U.

6-3. Replacement of Tubes

Caution: Do not rock or rotate a tube when removing it from its socket; use a tube puller and pull the tube straight out.

a. General. Before replacing any tubes, check the power cord and fuses as the possible source of trouble. If the trouble is not found, follow the instructions given in *b* and *c* below to check the tubes.

b. Use of Tube Tester. Remove and test one tube at a time. Discard a tube only if a defect is obvious or the tube tester shows it to be defective. Do not discard a tube that tests at or near its minimum test limit. Replace the

original tube, or insert a new one if required, before testing the next one.

c. Tube Substitution Method. Replace a suspected tube with a new tube. If the equipment still does not work, remove the tube and put back the original tube. Repeat this procedure with each suspected tube until the defective tube is located.

Note. This method will not work when more than one tube is defective in the same circuit.

d. Critical Tube Replacement. Refer to paragraphs 6-5 and 6-6 for the procedure in selection of differential amplifier tube V6 and cathode follower tube V104.

6-4. Replacement of 60-Cycle Chopper

a. Remove the two securing screws at the rear of the vtvm.

b. Pull the chassis out of the case.

Caution: Do not rock or rotate a tube when removing it from a socket.

c. Remove tube V101 to gain access to chopper CK1.

d. Move the retaining clamp of chopper CK1.

e. Remove chopper CK1 and replace it with a new one.

f. Move the retaining clamp back on chopper CK1.

g. Replace tube V101.

h. Replace the chassis unit in the case and secure with the two screws.

6-5. Selection of Tube V6

a. *General.* This tube is a high-mu, dual-triode, type 12 AX7, used as a differential amplifier in the second series regulator. Poor regulation of the 500-volt reference power supply is commonly caused by poor balance between the halves of tube V6.

b. *Selection Procedure.*

(1) Install the replacement 12AX7 tube (V6).

(2) Connect the variac to the ac power source and the vtvm to the variac.

(3) Set the variac to deliver 115 volts.

(4) Set the front panel controls as follows:

(a) VOLTS RANGE switch to 500.

(b) NULL switch to VTVM.

(c) Voltage-divider switches A through E to 0.

(d) Power switch to ON.

(5) Allow 5 minutes for the vtvm to warmup.

Caution: Be careful when working on pins 4 and 9 of V6. A dc potential of 170 volts is present on these pins.

(6) Use the multimeter set and monitor the ac voltage between pins 4 and 9 of tube V6 as the line voltage is varied (by rotating the control on the variac) between 100 and 130 volts. Replace tube V9 if the total variation is greater than 0.5 volt.

(7) Return the line voltage to 115 volts,

(8) Use the vtvm and monitor the output of the 500-volt reference power supply between pin 3 of tube V4, and the - input terminal as the line voltage is varied between 100 and 130 volts.

(9) Reject tube V6 if the voltage monitored deviates more than 0.05 volt.

6-6. Selection of Tube V104

a. *General.* This tube is a medium-mu, dual-triode, type 12AU7, used in the balanced bridge circuit. The tube used as V104 must have good balance between its halves, and low grid current for satisfactory performance.

b. *Selection Procedure.*

(1) Install the replacement 12AU7 tube (V104).

(2) Connect the variac to the ac power source and the vtvm to the variac.

(3) Set the variac to deliver 115 volts.

(4) Set the front panel controls as follows:

(a) VOLTS RANGE switch to 500.

(b) NULL switch to VTVM.

(c) Voltage-divider switches A through E to 0.

(d) Power switch to ON.

(5) Allow 5 minutes for the vtvm to warm up.

(6) Use the multimeter set, and monitor the ac voltage between pins 9 and 4 of tube V104 as the line voltage is varied (by rotating the control on the variac) between 100 and 130 volts. Replace tube V104 if the total variation is greater than 0.5 volt.

(7) Return the line voltage to 115 volts.

(8) Adjust the VTVM-10V-1V ZERO control to zero the indicator of VOLTS meter M1. Reject tube V104 if the VTVM-10V-1V ZERO control is not within $\pm 90^\circ$ of vertical when the VOLTS meter M1 indicator is zeroed.

(9) Vary the line voltage between 100 and 130 volts'. Reject tube V104 if the VOLTS meter M1 indicator deflects more than two small-scale divisions on either side of zero.

(10) Return the line voltage to 115 volts

- (11) If necessary, adjust the VTVM-10V-1V ZERO control to zero the indicator of VOLTS meter M1.
- (12) Jumper the + and - input terminals together. Reject tube V104 if the VOLTS meter M1 indicator deflects more than one-quarter of one small-scale division on either side of zero.
- (2) Wipe the clear plastic strips that insulate the chassis from the metal frame with a clean, dry cloth. (If necessary, clean the clear plastic strips with a soft cloth saturated in a solution consisting of 70 percent Stoddard solvent, 5 percent perchlorethylene, and 25 percent methylene chloride.)

6-7. Cleaning Procedure

Note. If the vtvm has been stored in a hot, humid atmosphere, leakage resistance may be noted upon initial operation. This leakage resistance will appear as a higher than 10-percent meter M1 indicator deflection when the VOLTS RANGE switch is set to 500 and the NULL switch is rotated to 10, 1, .1, and .01. Permit the vtvm to warmup for approximately 5 minutes. If leakage resistance still exists, clean the vtvm as outlined in *a*, *b*, and *c* below.

With the VOLTS RANGE switch set to 500, the NULL switch set to 1, and voltage-divider switches A through E set to 4, 0, 0, 0, 0, respectively, leakage resistance of 40,000 megohms between pin 2 of V104A and the - input terminal will cause a 10-percent meter M1 indicator deflection. Lower values of leakage resistance will cause larger meter M1 indicator deflection with no connection to the + and - input terminals. Perform the procedures given in *a*, *b*, and *c* below to clean and remove the dust and foreign matter to prevent leakage resistance.

a. Cleaning Clear Plastic Strips.

- (1) Use a low-pressure dry air blower to blow out dust and foreign matter from the vtvm.

b. Cleaning Binding Post Insulator. Clean the binding post insulators with a clean cloth saturated in a solution consisting of 70 percent Stoddard solvent, 5 percent perchlorethylene, and 25 percent methylene chloride.

c. Cleaning VOLTS RANGE and NULL Wafer Switches.

- (1) Wash the wafer switches with a small, stiff-bristled brush dipped in a solution consisting of 70 percent Stoddard solvent, 5 percent perchlorethylene, and 25 percent methylene chloride.
- (2) After washing the wafer switches ((1) above), the ceramic surfaces of the wafer switches must be recoated with a mixture consisting of 10 percent Dow Corning 200 (100 viscosity grade) oil, and 90 percent cleaning solvent (cleaning solvent consists of 70 percent Stoddard solvent, 5 percent perchlorethylene, and 25 percent methylene chloride) to prevent moisture from collecting across the ceramic surfaces. (Do not apply grease or other lubricants to the switch wafers.)

Section II. ALIGNMENT

6-8. Alignment Preparation Procedure

The following procedures (*a* through *f* below and para 6-9) are to be performed whenever components are replaced or the need for alignment is indicated. These procedures are also an excellent check of the overall performance of the vtvm.

Caution: Perform the alignment procedures (*a* through *f* below and para 6-9) in a clean, draft-free room.

- a.* Connect the variac to the vtvm under test.
- b.* Remove the two screws that secure the vtvm under test in its case and slide the vtvm out of its case.
- c.* Set the variac for a 115-volt output.
- d.* Set the front panel controls on the vtvm under test as follows:
 - (1) VOLTS RANGE switch to 500.
 - (2) NULL switch to VTVM.
 - (3) Voltage-divider switches A through E to 0.
 - (4) Power switch to ON.
- e.* Turn on the meter test set and the digital voltmeter.
- f.* Allow 3 hours for the test equipment to come to operating temperature and stabilize before attempting any adjustments. After the 3-hour warmup period, proceed with the procedures given in paragraph 6-9.

6-9. Alignment Test Procedure

a. Line Voltage Check.

- (1) Adjust the VTVM-10V-1V ZERO control on the vtvm under test to zero the indicator on VOLTS meter M1 (after performing the procedures given in para 6-8).
- (2) Turn the NULL switch to .1.
- (3) Adjust the .1-.01 ZERO control to zero the indicator on VOLTS meter M1.
- (4) Turn the NULL switch to 1.
- (5) Vary the line voltage (by rotating the control on the variac) between 100 and 130 volts. The indicator on VOLTS meter M1 (lower scale) should not deflect more than two small-scale divisions on either side of zero.
- (6) Return the line voltage to 117 volts.

b. Regulated 500-Volt Check.

- (1) Set the front panel controls as follows:
 - (a) VOLTS RANGE switch to 500.
 - (b) NULL switch to VTVM.
 - (c) Voltage-divider switch A to 4.
 - (d) Voltage-divider switches B, C, and D to 9.
 - (e) Voltage-divider switch E to 10.
- (2) Connect the digital voltmeter to monitor the voltage between pin 3 of tube V4 and the - input terminal of the vtvm under test.
- (3) Vary the line voltage between 100 and 130 volts. The voltage at pin 3 of tube V4 should be +500 volts and should not vary more than ± 0.05 volt.
- (4) Disconnect the digital voltmeter test leads from the vtvm under test and slide the vtvm into its case.

c. ADJ CAL Check.

- (1) Connect the equipment as shown in figure 6-1.
- (2) Adjust the power supply for an output of 500 volts as monitored with the digital voltmeter.
- (3) Adjust the ratio set for an output of 500 volts.
- (4) Turn the NULL switch on the vtvm under test to 10.

- (5) Vary the ADJ CAL control for a zero indication on VOLTS meter M1. Turn the NULL switch to 1, .1, and .01 to verify that the ADJ CAL control is adjusted for a true null. The ADJ CAL control should be at approximately midrange when the null is attained. Potentiometer P6 may be adjusted to vary the position of the ADJ CAL control at null.
- (6) If potentiometer P6 requires adjustment, verify that the ADJ CAL control is adjusted for a null with the vtvm in its case and the NULL switch is set to .01 ((5) above). Do not further adjust the ADJ CAL control.
- (7) Turn off the power supply, and disconnect the ratio set from the vtvm under test.
- (8) With the vtvm under test in its case, observe VOLTS meter M1 and depress the CAL PUSH switch. There should be no meter M1 indicator deflection. If necessary, adjust potentiometer P2 until no deflection of the indicator on VOLTS meter M1 is observed.
- (9) Verify that no deflection of the indicator on VOLTS meter M1 is observed when the vtvm is in its case, and the CAL PUSH switch is depressed.

d. Full-Scale Adjust.

- (1) Connect the output of the ratio set to the input terminals of the vtvm under test.
- (2) Turn the NULL switch to VTVM.
- (3) Adjust the ratio set for an output of 0.5 volt with the power supply providing 500 volts, as monitored with the digital voltmeter.
- (4) Turn the VOLTS RANGE switch to .5.
- (5) The indicator on VOLTS meter M1 should indicate exactly full scale. If necessary, adjust potentiometer P104 to obtain an exact full-scale reading.
- (6) Turn the VOLTS RANGE switch to 500.
- (7) Adjust the ratio set for an output of 500 volts. The indicator on VOLTS meter M1 should indicate 500 volts (± 20 volts).

- (8) Adjust the ratio set for an output of 50 volts.
 - (9) Turn the VOLTS RANGE switch to 50. The indicator on VOLTS meter M1 should indicate 50 volts (± 2 volts).
- e. *Alignment Adjust (50 Volt).*
- (1) Turn the NULL switch to .01.
 - (2) Check for a zero indication on VOLTS meter M1. If necessary, adjust potentiometer P3 to obtain a zero indication on VOLTS meter M1 with the vtvm in its case.
 - (3) Turn the NULL switch to VTVM.
- f. *Alignment Adjust (5 Volts).*
- (1) Adjust the ratio set for an output of 5 volts.
 - (2) Turn the VOLTS RANGE switch to 5. The indicator on VOLTS meter M1 should indicate 5 volts (± 0.2 volt).
 - (3) Turn the NULL switch to .01 and check for a zero indication on VOLTS meter M1.
 - (4) If necessary, adjust potentiometer P4 to obtain a zero indication on VOLTS meter M1 with the vtvm in its case.
 - (5) Turn the NULL switch to VTVM.
- g. *Alignment Adjust (0.5 Volt).*
- (1) Adjust the ratio set for an output of 0.5volt.
- (2) Turn the VOLTS RANGE switch to .5. The indicator on VOLTS meter should indicate 0.5 volt (± 0.02 volt).
 - (3) Turn the NULL switch to .01 and check for a zero indication on VOLTS meter M1.
 - (4) If necessary, adjust potentiometer P5 to obtain a zero indication on VOLTS meter M1 with the vtvm in its case.
 - (5) Turn the NULL switch to VTVM, and the VOLTS RANGE switch to 500.
- h. *Gain Adjust.*
- (1) Adjust the power supply for an output of 10 volts, as monitored with the digital voltmeter.
 - (2) Adjust the ratio set for an output of 10 volts.
 - (3) Turn the VOLTS RANGE switch to 50.
 - (4) The indicator on VOLTS meter M1 should indicate 10 volts (± 0.4 volt).
 - (5) Adjust the ratio set for an output of 1 volt.
 - (6) Turn the VOLTS RANGE switch to 5. The indicator on VOLTS meter M1 should indicate 1 volt (± 0.04 volt).
 - (7) Adjust the ratio set for an output of 0.1 volt.

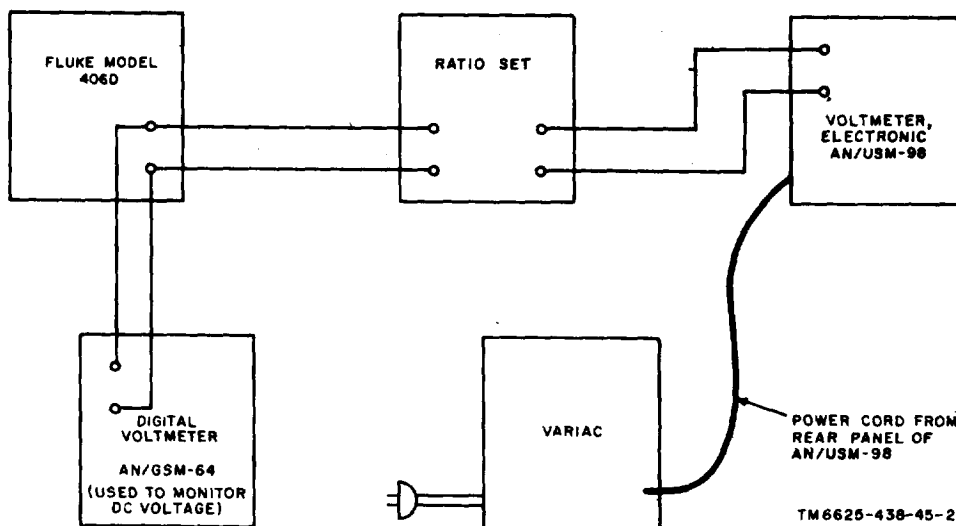

Figure 6-1. Voltmeter, Electronic AN/USM-98, alignment test setup.

- (8) Turn the VOLTS RANGE switch to .5.
- (9) Turn the NULL switch to .1. If necessary, adjust potentiometer P103 to obtain an exact full-scale deflection of the indicator on VOLTS meter M1 with the vtvm in its case.
- (10) Adjust the ratio set for an output of 0.01 volt.
- (11) Turn the NULL switch to .01. The indicator on VOLTS meter M1 should indicate 0.01 volt (± 0.004 volt).

i. Faulty Decade Resistor Check.

- (1) Turn off the output of the power supply.
- (2) Connect the output of the power supply directly to the input terminals of the vtvm under test.
- (3) Set the front panel controls as follows:
 - (a) VOLTS RANGE switch to 500.
 - (b) NULL switch to VTVM.
 - (c) Voltage-divider switch A to 4.
 - (d) Voltage-divider switches B, C, D, and E to 0.
- (4) Adjust the power supply for an output of 400 volts.
- (5) Turn the NULL switch to 10, and adjust the meter test set for a null indication on VOLTS meter M1.
- (6) Turn the NULL switch to 1, and adjust the meter test set for a null indication on VOLTS meter M1. Do not further adjust the meter test set.
- (7) Turn the NULL switch to VTVM.
- (8) Set voltage-divider switches A through E as follows:
 - (a) Voltage-divider switch A to 3.
 - (b) Voltage-divider switches B, C, and D to 9.
 - (c) Voltage-divider switch E to 10.
- (9) Turn the NULL switch to 1. The indicator on VOLTS meter M1 should

not deviate more than 0.2 volt on either side of zero.

- (10) Turn the NULL switch VTVM.
- (11) Adjust the power supply for an output of 50 volts.
- (12) Set the voltage-divider switches as follows:
 - (a) Voltage-divider switch A to 0.
 - (b) Voltage-divider switch B to 5.
 - (c) Voltage-divider switches C, D, and E to 0.
- (13) Turn the NULL switch to 10, and adjust the power supply for a null indication on VOLTS meter M1.
- (14) Turn the NULL switch to 1, and adjust the power supply for a null indication on VOLTS meter M1. Do not further adjust the power supply.
- (15) Turn the NULL switch to VTVM.
- (16) Set the voltage-divider switches as follows:
 - (a) Voltage-divider switch A to 0.
 - (b) Voltage-divider switch B to 4.
 - (c) Voltage-divider switches C and D to 9.
 - (d) Voltage-divider switch E to 10.
- (17) Turn the NULL switch to 1. The indicator on VOLTS meter M1 should not deviate more than 0.025 volt on either side of zero.
- (18) A faulty resistor in the voltage-divider switches A through E decade is indicated if VOLTS meter M1 deviation ((9) or (17) above) is beyond limits.
- (19) Turn off all the test equipment and disconnect all the test leads.

j. Apply glyptal, or suitable substitute, to ali screwdriver adjustments which were adjusted during the alignment procedure to make sure they are not mistakenly moved in the future.

k. Secure the vtvm in its case.

CHAPTER 7

GENERAL SUPPORT TESTING PROCEDURES

7-1. General

a. Testing procedures are prepared for use by Electronics Field Maintenance Shops and Electronics Service Organizations responsible for general support maintenance of electronic repaired equipment to determine the acceptability of repaired equipment. These procedures set forth specific requirements that repaired equipment must meet before it is returned to the using organization. These procedures may also be used as a guide for testing equipment that has been repaired at direct support maintenance if the proper tools and test equipments are available.

b. Comply with the instructions preceding each chart before proceeding to the chart. Per-

form each step in sequence. Do not vary the sequence. For each step, perform all the actions required in the Control settings columns; then perform each specific test procedure and verify it against its performance standard.

7-2. Test Equipment Required

All the test equipment required to perform the testing procedures given in this chapter are listed in the chart below, and are authorized under TA 11-17, Signal Field Maintenance Shop-s, and TA 11-100 (11-17), Allowances of Army Corps Expendable Supplies for Signal Field Maintenance Shop, Continental United States.

Nomenclature	Federal stock No.	Technical manual
Power Supply, John Fluke Model 406D, or equal.	6130-583-9946	
Voltmeter, Digital AN/GSM-64 -- Dc Ratio Standard, Gertsh Model 1001, or equal.	-----	TM 11-6625-444-15
Variable transformer CN-16A/U.	5960-235-2086	
Multimeter TS-352B/U -----	-----	TM 11-6625-366-15

7-3. Modification Work Orders

The performance standards listed in the tests (para 7-4, 7-5, and 7-6) are based on the

assumption that all modification work orders on this equipment have been performed. A listing of current modification work orders will be found in DA Pam 310-4.

7-4. Physical Tests and Inspections

- a. *Test Equipment.* None required.
- b. *Test Connections and Conditions.*
 - (1) No connections are necessary.
 - (2) Remove the cover from the vtvm.
- c. *Procedure.*

Step No.	Control settings		Test procedure	Performance standard
	Test equipment	Equipment under test		
1	N/A	Controls may be in any position.	<p>a. Inspect case and chassis for damage, missing parts, and condition of paint.</p> <p><i>Note.</i> Touchup painting is recommended in lieu of refinishing whenever practicable. Screwheads, binding posts, receptacles, and other plated parts will not be painted or polished with abrasives.</p> <p>b. Inspect all controls and mechanical assemblies for loose or missing screws, bolts, and nuts.</p> <p>c. Inspect all connectors, sockets, receptacles, and fuseholders for looseness, damage, or missing parts.</p>	<p>a. No damage evident or parts missing. External surfaces intended to be painted do not show bare metal. Panel lettering is legible.</p> <p>b. Screws, nuts, and bolts are tight, and none are missing.</p> <p>c. No looseness or damage evident.</p>
2	N/A	Controls may be in any position.	<p>a. Rotate all panel controls throughout their limits of travel.</p> <p>b. Operate all switches</p>	<p>a. Controls rotate freely without binding or excessive looseness.</p> <p>b. Switches operate properly.</p>

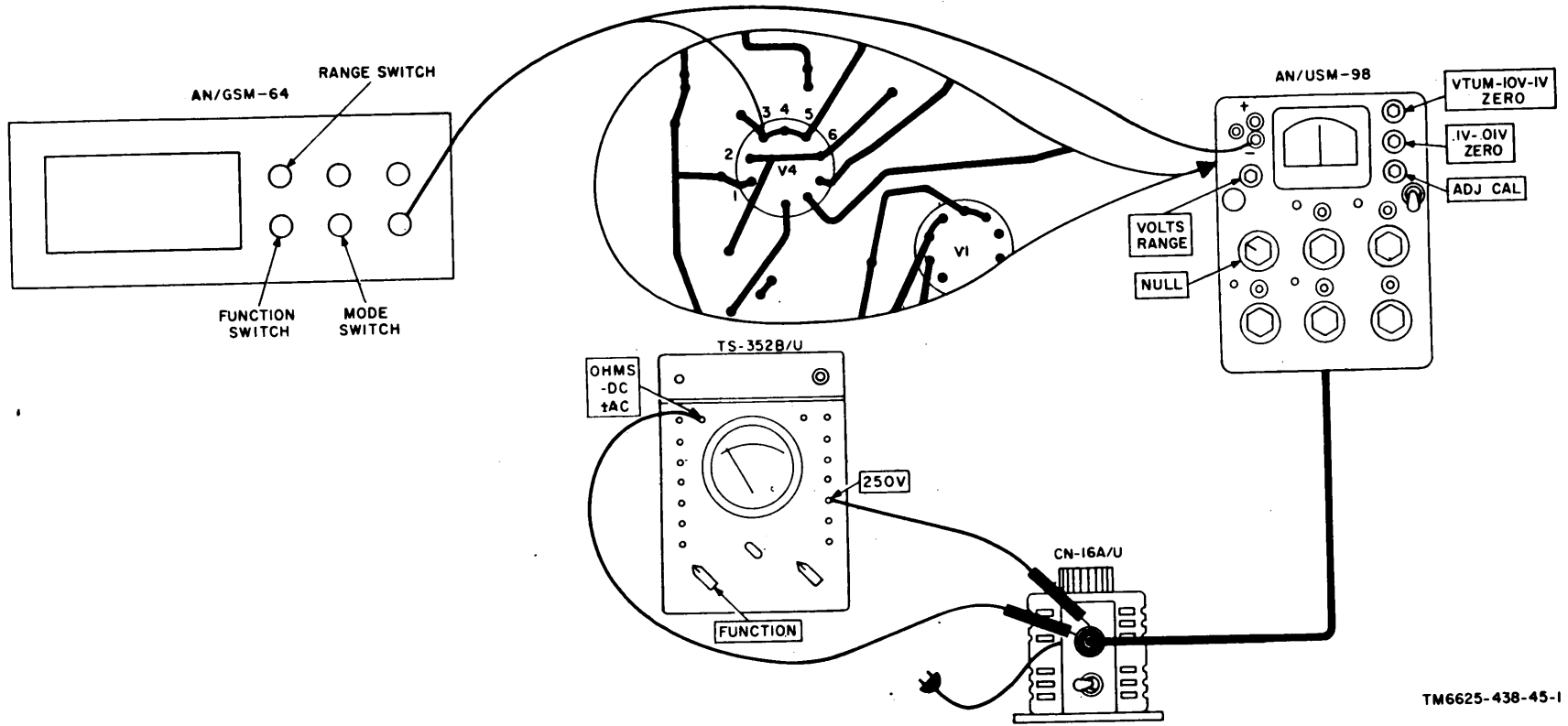

Figure 7-1. Internal reference power supply accuracy test.

CHAPTER 8

DEPOT OVERHAUL STANDARDS

8-1. Applicability of Depot Overhaul Standards

The tests outlined in paragraphs 8-4 through 8-10 are designed to measure the performance capability of a repaired equipment. Equipment that is to be returned to stock should meet the standards given in these tests.

8-2. Applicable References

a. Repair Standards. Applicable procedures of the depots performing these tests, and the

general standards for repaired electronic equipment given in TB SIG 355-1, TB SIG 355-2, and TB SIG 355-3 form a part of the requirements for testing this equipment.

b. Modification Work Orders. Perform all modification work orders applicable to this equipment before making the tests specified. DA Pam 310-4 lists all available MWO'S.

8-3. Test Facilities Required

The following test equipments are required for depot testing:

Nomenclature	Technical manual	Common name
Voltmeter, Digital AN/GSM-64 --	TM 11-6625-444-15	Digital voltmeter.
Voltmeter IS-185 -----	-----	Ac voltmeter.
John Fluke Model 406D Power Supply, or equal.	-----	Power supply.
Variable Transformer CN-16A/U.	-----	Variable transformer.

8-4. General Test Requirements

Most of the tests will be performed under the conditions given in *a* through *d* below, and as illustrated in figure 8-1.

a. Connect the equipment under test to a 117-volt ac power source through the variable transformer.

b. Connect the ac voltmeter across the power output section of the variable transformer.

c. The meter needle should be at, or mechanically adjusted to zero prior to placing the power switch to ON.

d. Always allow at least 10 minutes for all equipment to reach stabilized temperatures.

8-5. Zero Adjust Test

Connect the equipment as shown in figure 5-1.

a. Set the power switch to ON, the VOLTS RANGE switch to 500, the NULL switch to VTVM, and voltage-divider indicators A through E to zero.

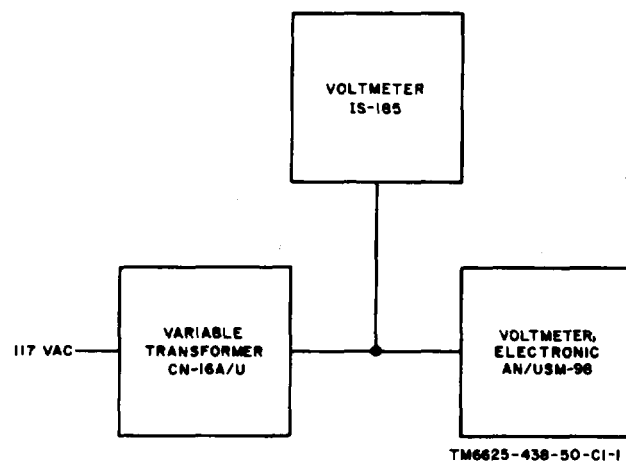

Figure 8-1. Connections for find testing.

- b. The decimal point indicator lamp to the left of the D indicator should glow.
- c. Set the NULL switch to 1, and adjust the VTVM-10V-1V ZERO control so that the volts meter needle is at zero.
- d. Rotate the NULL switch to 10.
- e. The volts meter needle should remain at zero.
- f. Rotate the NULL switch to .01 and adjust the .1V-.01V ZERO control so that the volts meter needle is at zero.
- g. Rotate the NULL switch to .1.
- h. The volts meter needle should remain at zero.
- i. The .1V-.01V ZERO control should be capable of varying the volts meter needle position to a minimum of five small divisions on both sides of zero when the NULL switch is in the .1 position.
- j. Rotate the NULL switch to .01 and the A voltage-divider control to 4.
- k. After the volts meter needle has stabilized, it should be within two small divisions of zero.

8-6. Calibration Test

- a. Set the NULL switch to VTVM, voltage divider switches A through E to 0, and the VOLTS RANGE switch to CAL.
- b. With the CAL PUSH switch depressed, the ADJ CAL control should be capable of adjusting the volts meter needle to zero.

8-7. Vtvm Accuracy Test

Connect the power supply and the digital voltmeter to the AN/USM-98, as shown in figure 8-2.

- a. Set the VOLTS RANGE switch to 500, and the NULL switch to VTVM.
- b. Adjust the power supply output to 400.00 volts dc, as indicated on the digital voltmeter.
- c. With the positive output lead of the power supply connected to the + input terminal of the AN/USM-98, and the negative output lead connected to the - input terminal, the volts meter needle should indicate 400 ±20 volts on the right-hand section of the volts meter scale.
- d. Transpose the input leads from the power supply. The volts meter should indicate 400

±20 volts on the left-hand section of the volts meter scale.

e. Readjust the power supply output to 100.00 volts dc, as indicated on the digital voltmeter.

f. With the power supply output connected (c above), the volts meter needle should indicate 100 ±20 volts in the right-hand section of the volts meter scale.

g. With the power supply connected (d above), the volts meter needle should indicate 100 ±20 volts on the left-hand section of the volts meter scale.

h. Repeat the procedure given in a, b, and c above, except the control settings and readings should be as follows:

VOLTS RANGE switch	Power supply output (volts)	AN/USM-98 indication and tolerance (volts)
50	40.000	40 ±2
50	10.000	10 ± 2
5	4.0000	4 ± 0.2
5	1.0000	1 ± 0.2
.5	0.4000	0.4 ± 0.02
.5	0.1000	0.1 ± 0.02

8-8. Accuracy and Stability Test, 500-Volt Divider

Connect the variable transformer, the power supply, the digital voltmeter, and the AN/USM-98, as shown in figures 8-1 and 8-2.

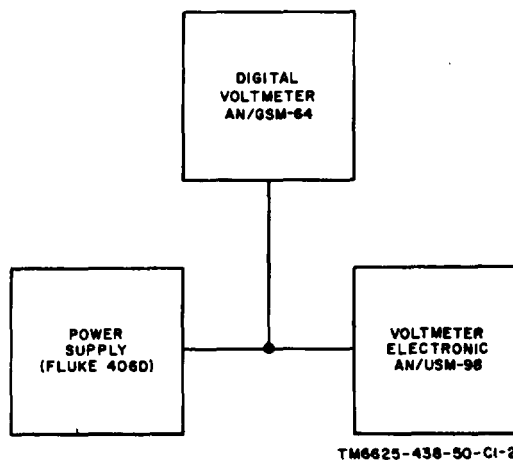

TM6625-438-50-C1-2

Figure 8-2. Connections for calibration and accuracy testing.

a. Zero-adjust the volts meter needle with the NULL switch in the .01 position; use the applicable portions of the procedure given in paragraph 30.

b. Rotate the NULL switch to the 1 position; adjust the voltage controls to 495.00.

c. Adjust the power supply output to 495.00 volts dc, as indicated on the digital voltmeter.

d. Readjust the voltage controls for a null indication.

e. The voltage indicators should read between 494.70 and 495.30.

f. Readjust the variable transformer so that the ac voltmeter indicates 105 volts ac.

g. Readjust the voltage controls for a null indication.

h. The voltage indicators should read within ± 0.05 volt of the reading obtained in e above.

i. Readjust the variable transformer so that the ac voltmeter indicates 130 volts ac.

j. Readjust the voltage controls for a null indication.

k. The voltage indicators should read within ± 0.05 volt of the reading obtained in e above.

8-9. Accuracy Test, 50-, 5-, 0.5-Volt Dividers

a. Readjust the variable transformer so that the ac voltmeter indicates 117 volts ac.

b. Repeat the procedure given in para-

graph 8-8a through e, except the control settings and readings should be as follows:

Power supply	Volts range	Null	Voltage-divider (at null)	Indicators
40.000	50	.1	39.976	to 40.024
4.0000	5	.01	3.9976	to 4.0024
0.4000	0.5	.01	.39972	to .40028

8-10. Attenuator Accuracy Test

a. With the NULL switch at VTVM set the VOLTS RANGE switch to 500, the voltage controls to 400.00, and the power supply to 400.00 volts dc.

b. Readjust the NULL switch to the .1 position, and readjust the power supply for a null indication of the volts meter needle.

c. Turn the NULL switch to VTVM, and reset the voltage controls to 399.910.

d. Turn the NULL switch to the .1 position. The volts meter needle should indicate within ± 0.8 of null on the lower volts meter scale.

e. Readjust the NULL switch to VTVM, the voltage controls to 050.00, and the power supply to 50.000 volts dc.

f. Turn the NULL switch to the .1 position, and readjust the power supply for a null indication of the volts meter needle.

g. Turn the NULL switch to VTVM, and reset the voltage controls to 049.910.

h. Turn the NULL switch to the .1 position. The volts meter needle should indicate within $\pm .25$ of null on the lower volts scale.

CHAPTER 9

SHIPMENT, LIMITED STORAGE, AND DEMOLITION TO PREVENT ENEMY USE

Section I. SHIPMENT AND LIMITED STORAGE

9-1. Disassembly of Equipment

To prepare the vtvm for shipment or storage, proceed as follows:

- a. Disconnect the vtvm from the power source.
- b. Check to see that the two screws (fig. 1-2) that hold the case are tight.
- c. Roll up the power cord and store it behind the vtvm.
- d. Roll up the test leads and place them in a waterproof envelope for later packaging.

9-2. Repackaging for Shipment or Limited Storage

a. *General.* The exact procedure in repackaging depends on the material available and the conditions under which the equipment is to be shipped or stored. Adapt the procedures given in *b* and *c* below whenever circumstances permit. The information concerning the original packaging (para 2-1 and fig. 2-1) will also be helpful.

b. *Material Requirements.* The following materials are required for packaging Voltmeter,

Electronic AN/USM-98. For stock numbers of materials, consult SB38-100.

Material	Quantity
Waterproof paper -----	36 sq ft
Waterproof tape -----	20 ft
Cotton twine -----	50 ft
Corrugated cardboard -----	36 sq ft
Gummed tape -----	20 ft
Filler material-----	8 lb

c. *Packaging.* Package the vtvm as outlined below:

- (1) Cushion the vtvm on all the surfaces with pads of the filler material.
- (2) Place the cushioned unit within a wrap of corrugated cardboard.
- (3) Secure the wrap with the gummed tape.

9-3. Handling, Storage, and Disposal of Radioactive Material

Follow the procedures for safe handling, storage, and disposal of radioactive materials as directed by TB SIG 225, AR 700-52 and AR 755-380.

Section II. DEMOLITION OF MATERIAL TO PREVENT ENEMY USE

9-4 Authority for Demolition

The demolition procedures given in paragraph 9-5 will be used to prevent the enemy from using or salvaging this equipment. Demolition of the equipment will be accomplished only upon the order of the commander.

9-5. Methods of Destruction

Any or all of the methods of destruction given in a through d may be used. The time

available will be the major determining factor for the methods to be used in most instances when destruction of equipment is undertaken. The tactical situation also will determine in what manner the destruction order will be carried out. In most cases, it is preferable to demolish completely some portions of the equipment rather than to partially destroy all the equipment units.

a. Smash. Smash the case and the interior units; use sledges, axes, hammers, crowbars, or heavy tools. Remove the chassis from the case and smash the VOLTS meter, the tubes, the knobs, and the controls. Bend the case and the chassis frame.

b. Cut. Cut the cabling, the cording, and the wiring; use axes, handaxes, machetes, or similar cutting tools. Cut the power cord, the test leads, and the wiring harness in a number of places.

Warning: Be extremely careful with explosives and incendiary devices. Use these items only when the need is urgent.

c. Burn. Burn the resistors, the capacitors, the wiring, the records, and the technical manuals; use gasoline, kerosene, oil, flare-throwers, or incendiary grenades.

d. Dispose. Bury or scatter the destroyed parts, or throw them into waterways. This is particularly important if a number of the parts have not been completely destroyed.

COLOR CODE MARKING FOR MILITARY STANDARD RESISTORS

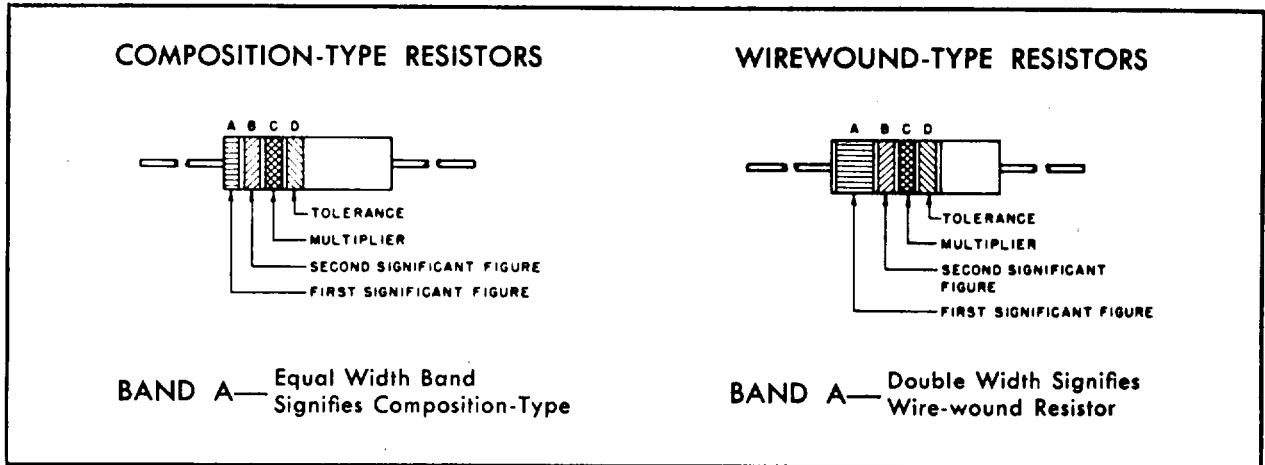

COLOR CODE TABLE

BAND A		BAND B		BAND C		BAND D*	
COLOR	FIRST SIGNIFICANT FIGURE	COLOR	SECOND SIGNIFICANT FIGURE	COLOR	MULTIPLIER	COLOR	RESISTANCE TOLERANCE (PERCENT)
BLACK	0	BLACK	0	BLACK	1		
BROWN	1	BROWN	1	BROWN	10		
RED	2	RED	2	RED	100		
ORANGE	3	ORANGE	3	ORANGE	1,000		
YELLOW	4	YELLOW	4	YELLOW	10,000	SILVER	± 10
GREEN	5	GREEN	5	GREEN	100,000	GOLD	± 5
BLUE	6	BLUE	6	BLUE	1,000,000		
PURPLE (VIOLET)	7	PURPLE (VIOLET)	7				
GRAY	8	GRAY	8	SILVER	0.01		
WHITE	9	WHITE	9	GOLD	0.1		

EXAMPLES OF COLOR CODING

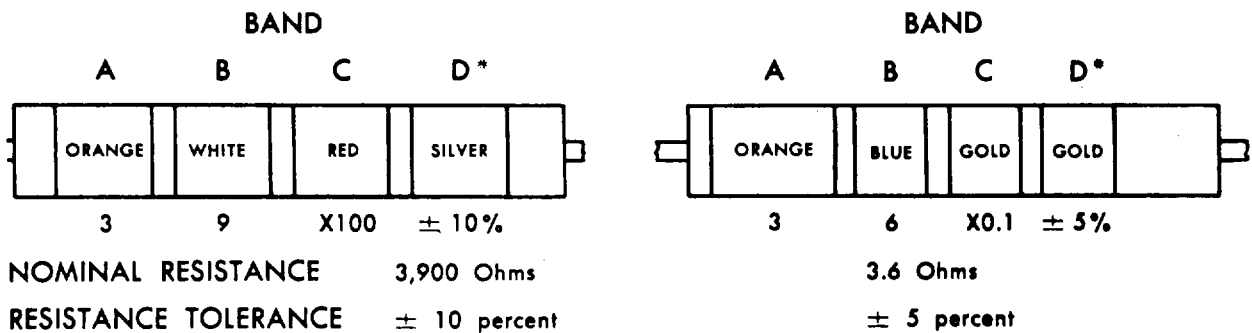

NOMINAL RESISTANCE 3,900 Ohms
RESISTANCE TOLERANCE ± 10 percent

3.6 Ohms
± 5 percent

STD-R2

*If Band D is omitted, the resistor tolerance is ± 20%, and the resistor is not Mil-Std.

Figure 9-1. MIL-STD resistor color code markings.

APPENDIX A

REFERENCES

AR 700-52	Licensing and Control of Ionizing Radiation.
AR 700-58	Report of Packaging and Handling Deficiencies.
AR 755-15	Disposal of Unwanted Radioactive Material.
DA Pam 310-4	Index of Technical Manuals, Technical Bulletins, Supply Manuals (types 7, 8, and 9), Supply Bulletins, Lubrication Orders, and Modification Work Orders.
SB 38-100	Preservation, Packaging, and Packing Materials, Supplies, and Equipment Used by The Army.
TA 11-17	Signal Field Maintenance Shop.
TA 11-100 (11-17)	Allowances of Army Corps Expendable Supplies for Signal Field Maintenance Shops.
TB SIG 225	Identification and Handling of Radioactive Signal Items.
TB SIG 355-1	Depot Inspection Standard for Repaired Signal Equipment.
TB SIG 355-2	Depot Inspection Standard for Refinishing Repaired Signal Equipment.
TB SIG 355-3	Depot Inspection Standard for Moisture and Fungus Resistant Treatment.
TB SIG 364	Field Instructions for Painting and Preserving Electronics Command Equipment.
TM 11-6625-274-12	Operator's and Organizational Maintenance Manual: Tests Sets, Electron Tube TV-7/U, TV-7A/U, TV-7B/U, and TV-7D/U.
TM 11-6625-366-15	Organizational, DS, GS, and Depot Maintenance Manual: Multimeter TS-352B/U.
TM 11-6625-444-15	Operator, Organizational, Field and Depot Maintenance Manual: Digital Voltmeters AN/GSM-64 and V-34A.
TM 38-750	Army Equipment Record Procedures.

APPENDIX C

MAINTENANCE ALLOCATION

Section I. INTRODUCTION

C-1. General

This appendix provides a summary of the maintenance operations covered in the equipment literature for Voltmeter, Electronic AN/USM-98. It authorizes categories of maintenance for specific maintenance functions on repairable items and components and the tools and equipment required to perform each function. This appendix may be used as an aid in planning maintenance operations.

C-2. Explanation of Format for Maintenance Allocation Chart

a. Group Number. Not used.

b. Component Assembly Nomenclature. This column lists the item names of component units, assemblies, subassemblies, and modules on which maintenance is authorized.

c. Maintenance Function. This column indicates the maintenance category at which performance of the specific maintenance function is authorized. Authorization to perform a function at any category also includes authorization to perform that function at higher categories. The codes used represent the various maintenance categories as follows:

Code	Maintenance Category
C	Operator/Crew
O	Organizational Maintenance

Code	Maintenance Category
F	Direct Support Maintenance
H	General Support Maintenance
D	Depot Maintenance

d. Tools and Equipment. The numbers appearing in this column refer to specific tools and equipment which are identified by these numbers in section III.

e. Remarks. Self explanatory.

C-3. Explanation of Format for Tool and Test Equipment Requirements

The column in the tool and test equipment requirements chart are as follows:

a. Tools and Equipment. The numbers in this column coincide with the numbers used in the tools and equipment column of the MAC. The numbers indicate the applicable tool for the maintenance function.

b. Maintenance Category. The codes in this column indicate the maintenance category normally allocated the facility.

c. Nomenclature. This column lists tools, test, and maintenance equipment required to perform the maintenance functions.

d. Federal Stock Number. This column lists the Federal stock number.

e. Tool Number. Not used.

SECTION II. MAINTENANCE ALLOCATION CHART

C-2

MAINTENANCE ALLOCATION CHART														
GROUP NUMBER	COMPONENT ASSEMBLY NOMENCLATURE	MAINTENANCE FUNCTIONS										TOOLS AND EQUIPMENT	REMARKS	
		INSPECT	TEST	SERVICE	ADJUST	ALIGN	CALIBRATE	INSTALL	REPLACE	REPAIR	OVERHAUL			REBUILD
	VOLTMETER, ELECTRONIC AN/USM-98	C	H	C	H		H						1,2,4,5,6,7,8 9 8 1,4,5,6,7,8 1,3,4,5,6,7,8 8	Visual
	VOLTMETER, ELECTRONIC ME-161/U									H		D		Functions are listed for end item AN/USM-98
	TEST LEAD SET CX-1331/U	C	H							H			1 8	Visual

TM 11-6625-438-15

SECTION III. TOOL AND TEST EQUIPMENT REQUIREMENTS

TOOL AND TEST EQUIPMENT REQUIREMENTS

TOOLS AND EQUIPMENT	MAINTENANCE CATEGORY	NOMENCLATURE	FEDERAL STOCK NUMBER	TOOL I
		AN/USM-98 (continued)		
1	H,D	MULTIMETER TS-352B/U	6625-553-0142	
2	H	TEST SET, ELECTRON TUBE TV-7D/U	6625-820-0064	
3	D	TEST SET, ELECTRON TUBE TV-2()/U	6625-849-5694	
4	H,D	TRANSFORMER CN-16/U	5950-235-2086	
5	H,D	VOLTMETER, DIGITAL AN/GSM-64	6625-870-2264	
6	H,D	VOLTMETER, AC IS-185	6625-405-6608	
7	H,D	POWER SUPPLY FLUKE MODEL 406D	6130-583-9946	
8	H,D	TOOL EQUIPMENT TK-21/G	5180-408-2391	
9	O	TOOLS AND TEST EQUIPMENT AUTHORIZED TO OPERATOR-REPAIRMAN BY VIRTURE OF HIS ASSIGNED MISSION		

GLOSSARY

Differential voltmeter— A type of voltmeter that measures an unknown voltage by comparing it with a known, variable voltage. The difference, or differential, is indicated by a meter circuit. When the internal, known voltage is varied until it is equal to the voltage being measured, as indicated by zero meter deflection, the unknown voltage is determined.

Input resistance ohms/volt— The amount of impedance presented by a voltmeter to a source of electromagnetic force when measuring voltage.

Nominal value— A usual or expected value, not

necessarily a specific or fixed value, except under given conditions.

Null— The condition where one value cancels the effect of another.

Resolution— The smallest increment that can be observed or measured.

Sixty-cycle chopper— A vibrating or oscillating device used to connect a circuit alternately to two different circuits or points 60 times per second. The contact arm is moved by a coil energized by a 60-cps filament supply.

Voltage excursion— The deviation or variation of voltage about a given value; usually referred to in describing instability of dc voltages.

INDEX

	Paragraph	Page
Accuracy and stability test, 500-volt divider	8-8	8-2
Accuracy Tests, 50-, 5-, 0.5-volt dividers	8-9	8-3
Alignment:		
Accuracy test	7-6	7-7
Preparation procedure	6-8	6-3
Test procedure	6-9	6-4
Applicability, depot overhaul standards	8-1	8-1
Applicable references	3-2	8-1
Attenuator accuracy test	8-10	8-3
Authority, demolition	9-4	9-1
Balanced bridge	4-3	4-4
Block diagram	4-2	4-1
Calibration test	8-6	8-2
Checking unpacked equipment	2-2	2-1
Chopper amplifier	4-5	4-10
Cleaning	3-8	3-3
Cleaning procedure	6-7	6-3
Components, Voltmeter, Electronic AN/USM-98	1-6	1-2
Controls and indicators	2-3	2-3
Description, vtm	1-7	1-2
Differential voltmeter operation	2-7	2-6
Disassembly, equipment	9-1	9-1
Fault indication (pertaining to decade resistors)	5-6	5-12
Fault test procedures	5-7	5-13
Forms and records.....	1-3	1-1
General	7-1	7-1
Instructions	5-1	5-1
Parts replacement techniques	6-1	6-1
Test requirements	8-4	8-1
Handling, storage, and disposal of radioactive material	9-3	9-1
Index publications	1-2	1-1
Internal differences, models	4-1	4-1
Internal reference power supply accuracy test	7-5	7-5
Low voltage power supply	4-6	4-11
Measuring high resistance	2-10	2-8
Methods of destruction	9-5	9-1
Modification work orders	7-3	7-1
Observing voltage excursions	2-8	2-7
operator's daily preventive maintenance checks and services chart	3-4	3-2
Organizational:		
Monthly preventive maintenance checks and services chart	3-6	3-2
Quarterly preventive maintenance checks and services chart	3-7	3-3
Weekly preventive maintenance checks and services chart	3-5	3-2
Organization, troubleshooting procedure	5-2	5-1

	Paragraph	Page
Physical tests and inspection -----	7-4	7-3
Preventive maintenance -----	3-2	3-1
Preventive maintenance checks and services periods -----	3-3	3-1
Purpose and use -----	1-4	1-1
Recording voltage excursions -----	2-9	2-3
Repacking, shipment or limited storage -----	9-2	9-1
Replacement:		
Decimal point indicator lamp -----	3-14	3-5
Fuse -----	3-12	3-5
Meter protective fuse -----	3-15	3 6
60-cycle chopper -----	6-4	6-2
Tubes (general support level) -----	6-3	6-1
Tubes (organizational level) -----	3-13	3-5
scope -----	1-1	1-1
Scope, maintenance -----	3-1	8-1
Selection, tube V6 -----	6-5	6-2
Selection, tube V104 -----	6-6	6-2
Starting procedure -----	2-5	2-4
Technical characteristics -----	1-5	1-1
Test equipment:		
And materials required -----	7-2	7-1
Required, repairs and alignment -----	6-2	6-1
Required, troubleshooting -----	5-3	5-2
Test facilities required -----	8-3	3-1
Touchup painting instructions -----	3-9	9-3
Troubleshooting chart -----	3-11, 5-5	3-4, 5-3
Troubleshooting sequence -----	6-4	6-3
Types operation -----	2-4	2-4
Unpacking -----	2-1	2-1
Vtvm accuracy test -----	8-7	3-2

By Order of the Secretary of the Army:

HAROLD K. JOHNSON,
General, United States Army,
Chief of Staff.

Official:

KENNETH G. WICKHAM,
Major General, United States Army,
The Adjutant General.

Distribution:

Active Army:

USASA (2)	USAC (3)	CHAD (3)
CNGB (1)	Svc Colleges (2)	ATAD (10)
CC-E (7)	USASCS (5)	Sig FLDMS (2)
Dir of Trans (1)	USASESCS (5)	AMS (1)
CofEngrs (1)	USAADS (2)	USAERDAA (2)
TSG (1)	USAAMS (2)	USAERDAW (13)
CofsptS (1)	USAARMS (2)	USACRREL (2)
USACDCEA (1)	USAIS (2)	Units org under fol TOE
USACDCCEA (1)	USAES (2)	(2 ea) :
USACDCOA (1)	USA Msl & Mun	6-155
USACDCQMA (1)	Can & Sch (5)	6-156
USACDCTA (1)	USATC (2)	6-185
USACDCADA (1)	WRAMC (1)	6-186
USACDCARMA (1)	Army Pic Cen (2)	6-216
USACDCAVNA (1)	USACDCEC (10)	6-345
USACDCARTYA (1)	Instl (2) except	6-346
USACDCSWA (1)	Ft Hancock (4)	6-385
USACDCCEA (Ft	Ft Gordon (10)	6-386
Huachuca) (1)	Ft Huachuca (10)	11-57
USAARENBD (2)	Ft Carson (25)	11-97
USAMC (2)	Ft Knox (12)	11-98
USCONARC (2)	WSMR (5)	11-117
ARADCOM (2)	Redstone Arsenal (5)	11-127
ARADCOM Rgn (1)	APG (5)	11-155
OS Maj Comd (2)	Gen Dep (2)	11-157
LOGCOMD (2)	Sig Dep (12)	11-158
USAMICOM (4)	Sig Sec Gen Dep (5)	11-500 (AA-AC)
USASTRATCOM (4)	Army Dep (2) except	11-587
USAESC (70)	LBAD (14)	11-592
MDW (1)	SAAD (30)	11-597
Armies (2)	TOAD (14)	44-235
Div (2)	LEAD (7)	44-236
Bde (2)	SHAD (3)	44-536
Div Arty (2)	NAAD (5)	44-568
Corps (2)	SVAD (5)	

NG: State AG (3); units—same as active Army except allowance is one copy to each unit.

USAR: None.

For explanation of abbreviations used see AR 320-50.

COLOR CODE MARKING FOR MILITARY STANDARD CAPACITORS

GROUP I Capacitors, Fixed, Various-Dielectrics, Styles CM, CN, CY, and CB

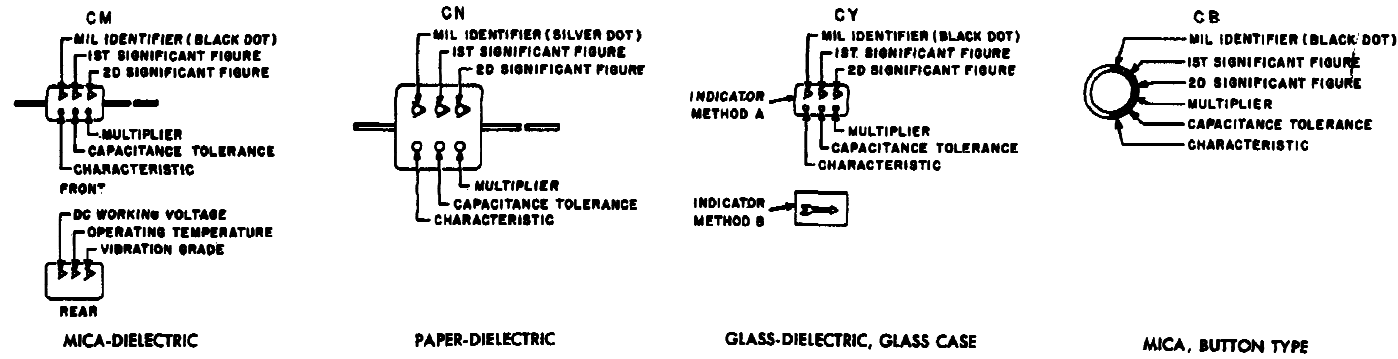

GROUP II Capacitors, Fixed Ceramic-Dielectric (General Purpose) Style CK

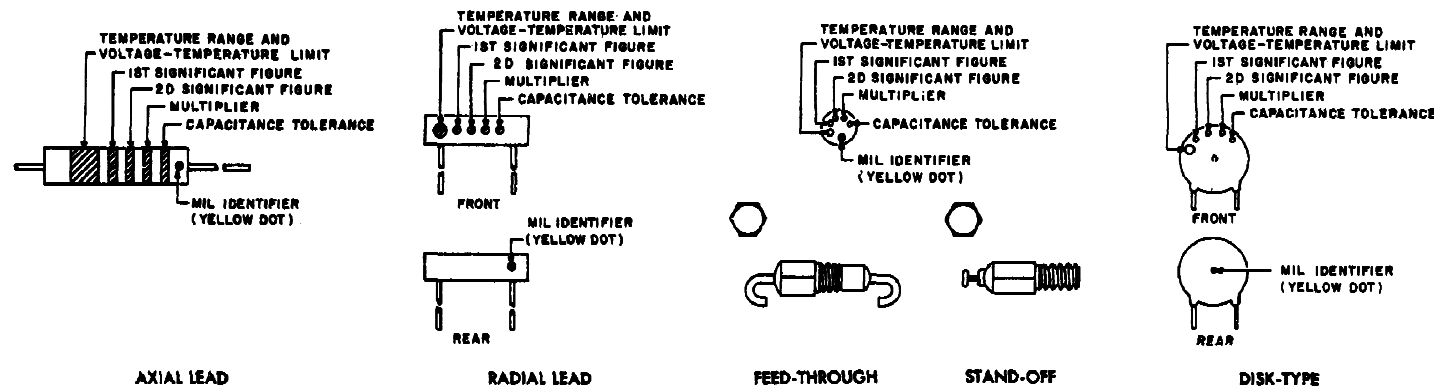

GROUP III Capacitors, Fixed, Ceramic-Dielectric (Temperature Compensating) Style CC

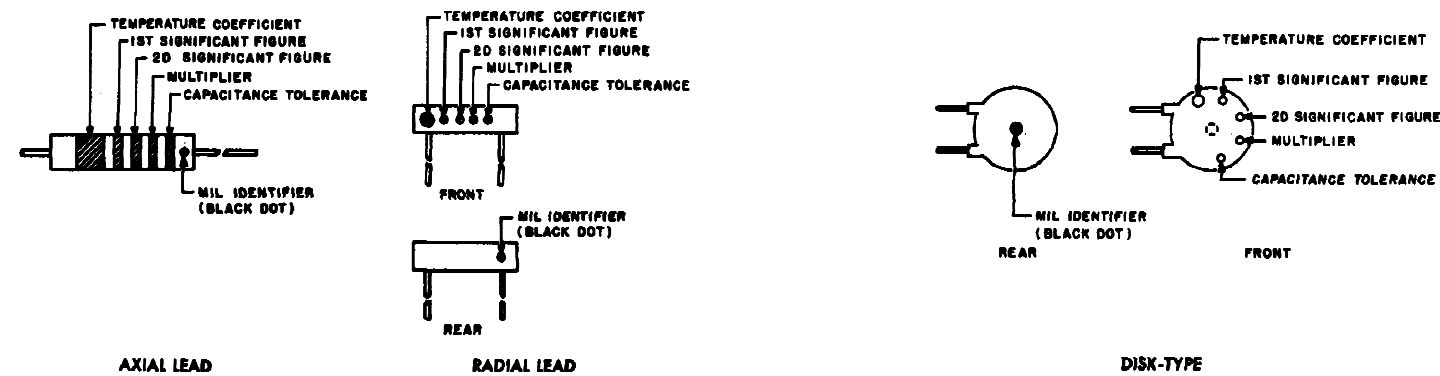

COLOR CODE TABLES

TABLE I - For use with Group I, Styles CM, CN, CY and CB

COLOR	MIL ID	1st SIG FIG	2nd SIG FIG	MULTIPLIER ¹	CAPACITANCE TOLERANCE				CHARACTERISTIC ²				DC WORKING VOLTAGE	OPERATING TEMP. RANGE	VIBRATION GRADE
					CM	CN	CY	CB	CM	CN	CY	CB	CM	CM	CM
BLACK	CM, CY, CB	0	0	1			± 20%	± 20%		A				-55° to +70°C	10-55 cps
BROWN		1	1	10					B	E	B				
RED		2	2	100	± 2%		± 2%	± 2%	C		C			-55° to +85°C	
ORANGE		3	3	1,000		± 30%			D		D	300			
YELLOW		4	4	10,000					E					-55° to +125°C	10-2,000 cps
GREEN		5	5		± 5%				F			300			
BLUE		6	6											-55° to +150°C	
PURPLE (VIOLET)		7	7												
GREY		8	8												
WHITE		9	9												
GOLD				0.1			± 5%	± 5%							
SILVER	CN				± 10%	± 10%	± 10%	± 10%							

TABLE II - For use with Group II, General Purpose, Style CK

COLOR	TEMP. RANGE AND VOLTAGE - TEMP. LIMITS ³	1st SIG FIG	2nd SIG FIG	MULTIPLIER ¹	CAPACITANCE TOLERANCE	MIL ID
BLACK		0	0	1	± 20%	
BROWN	AW	1	1	10	± 10%	
RED	AX	2	2	100		
ORANGE	BX	3	3	1,000		
YELLOW	AV	4	4	10,000		CK
GREEN	CZ	5	5			
BLUE	BV	6	6			
PURPLE (VIOLET)		7	7			
GREY		8	8			
WHITE		9	9			
GOLD						
SILVER						

TABLE III - For use with Group III, Temperature Compensating, Style CC

COLOR	TEMPERATURE COEFFICIENT ⁴	1st SIG FIG	2nd SIG FIG	MULTIPLIER ¹	CAPACITANCE TOLERANCE		MIL ID
					Capacitances over 10uuf	Capacitances 10uuf or less	
BLACK	0	0	0	1			CC
BROWN	-30	1	1	10	± 1%	± 2.0uuf	
RED	-80	2	2	100	± 2%	± 0.25uuf	
ORANGE	-150	3	3	1,000			
YELLOW	-220	4	4				
GREEN	-330	5	5		± 5%	± 0.5uuf	
BLUE	-470	6	6				
PURPLE (VIOLET)	-750	7	7				
GREY		8	8	0.01			
WHITE		9	9	0.1	± 10%		
GOLD	+100					± 1.0uuf	
SILVER							

- The multiplier is the number by which the two significant (SIG) figures are multiplied to obtain the capacitance in uuf.
- Letters indicate the Characteristics designated in applicable specifications: MIL-C-5, MIL-C-91, MIL-C-11272, and MIL-C-10950 respectively.
- Letters indicate the temperature range and voltage-temperature limits designated in MIL-C-11015.
- Temperature coefficient in parts per million per degree centigrade.

Figure 9-2. MIL-STD capacitor color code markings.

974

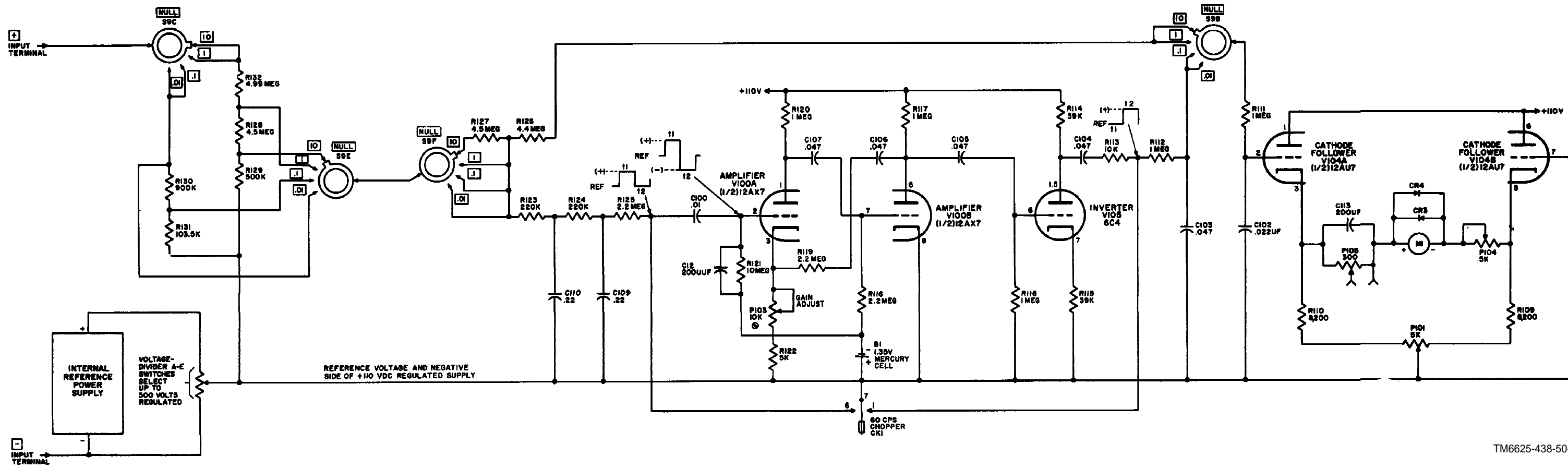
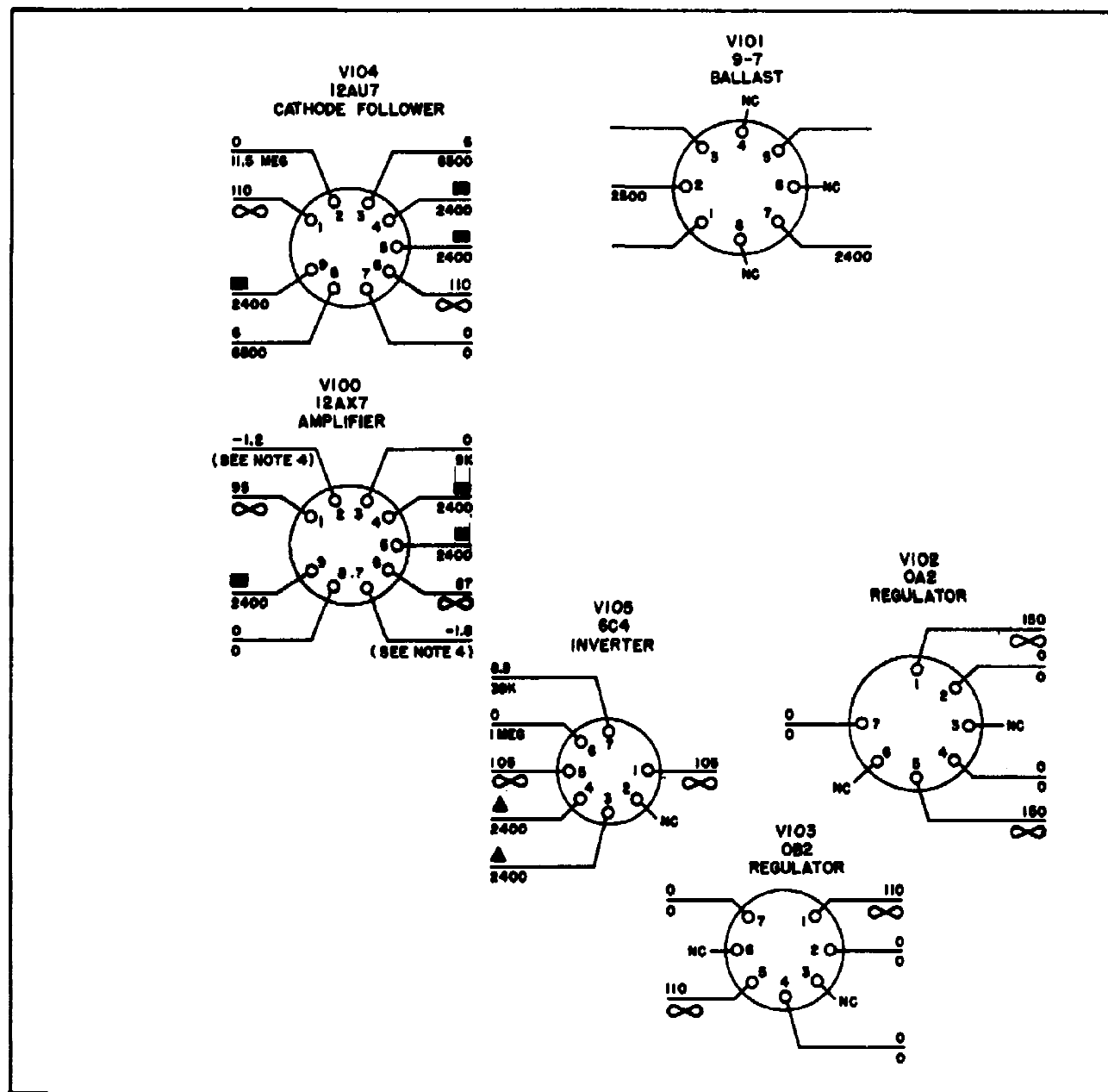

Figure 9-3. Differential voltmeter mode of operation, simplified schematic diagram.



A. CHOPPER AMPLIFIER PRINTED CIRCUIT BOARD.

NOTES:

1. ALL VOLTAGES AND RESISTANCES MEASURED WITH NEGATIVE PROBE TO INPUT TERMINAL AND TAKEN WITH TS-352(N)/U.
2. RESISTANCE IN OHMS, VOLTAGES ARE DC.
3. SWITCHES AND CONTROL SETTINGS AS FOLLOWS:
 VOLTS RANGE TO 500
 NULL TO VTVM
 ALL VOLTAGE DIVIDER SWITCHES TO ZERO
 .1V - .01V ZERO CONTROL TO MIDRANGE
4. DO NOT MEASURE RESISTANCE. BIAS CELL VOLTAGE IS PRESENT.
5. FILAMENT VOLTAGE FOR V4, V6, V100, AND V104 IS 6.3 VAC BETWEEN PINS 4, 5, AND 9.
6. FILAMENT VOLTAGE IS 5 VAC BETWEEN PINS 2 AND 8.
7. FILAMENT VOLTAGE FOR V2, V3, AND V105 IS 6.3 VAC BETWEEN PINS 3 AND 4.

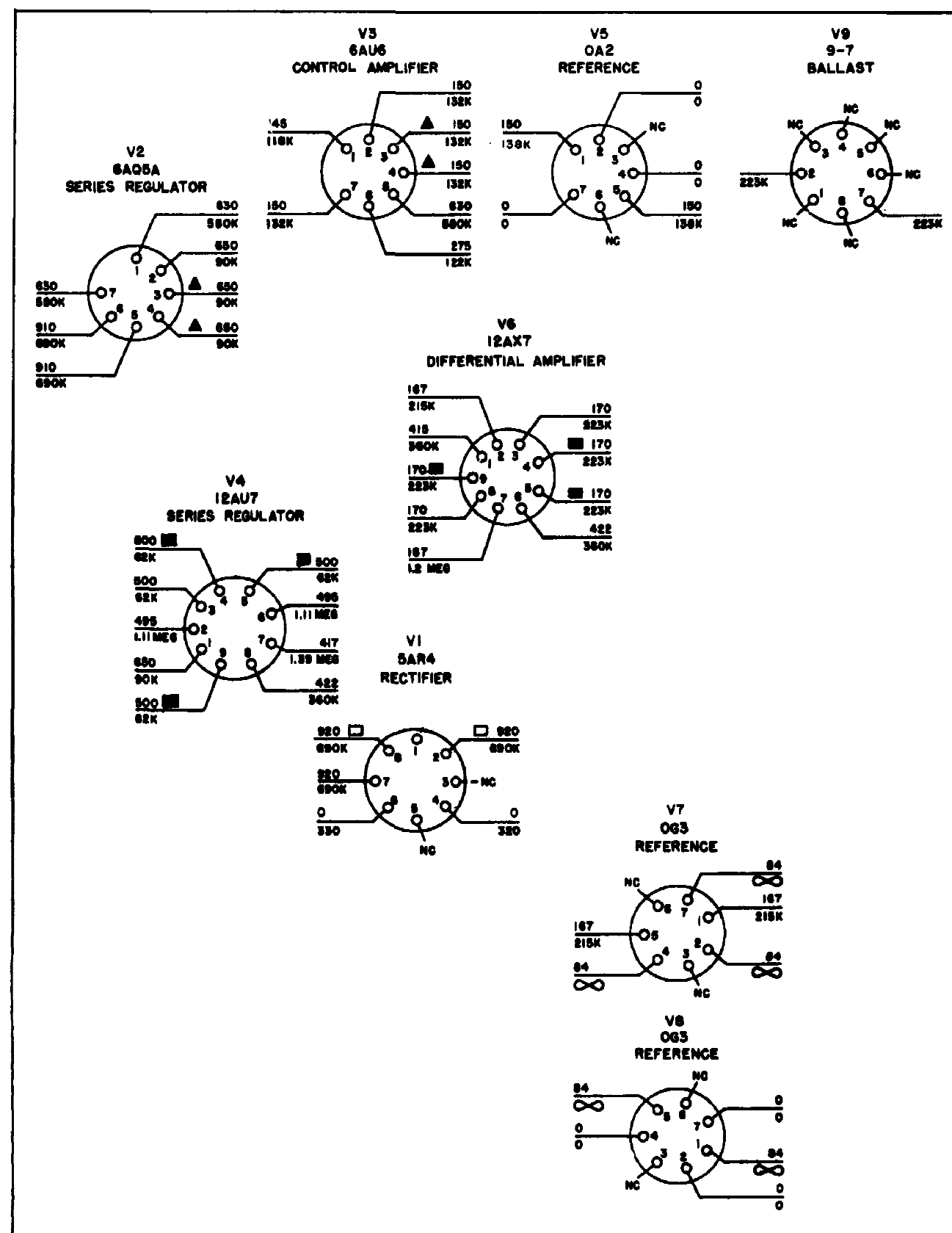

B. REFERENCE SUPPLY PRINTED CIRCUIT BOARD.

TM6625-438-50-2

Figure 9-4. Tube socket voltage and resistance diagram.

7-5. Internal Reference Power Supply Accuracy Test

a. Test Equipment Required.

- (1) Multimeter TS-352B/U.
- (2) Voltmeter, Digital AN/GSM-64.
- (3) Variable Transformer CN-16A/U.

b. Connections. Connect the equipment as instructed below and as indicated in figure 7-1.

c. Procedure.

Caution: Be careful when making connections in the test. Voltages up to 1,000 volts are present in these circuits.

Step No.	Control settings		Test procedure	Performance standard
	Test equipment	Equipment under test		
1	Controls may be in any position.	Controls may be in any position.	Turn on all test equipment, including the AN/USM-98. Let the equipment warm up for one-half of an hour or longer depending on the surrounding temperature.	None.
2	TS-352B/U: FUNCTION: AC	VOLTS RANGE switch: 500. NULL switch: VTVM. A, B, C, D, E: 0.	Connect the equipment as shown in figure 7-1. Adjust the CN-16A/U for 115 volts on the TS-352B/U.	Decimal point indicator lamp between C and D switches is illuminated.
3	Same as step 2.	Same as step 2.	<p>a. Adjust the VTVM-10V-1V ZERO control for a 0 reading on the VOLTS meter.</p> <p>b. Place the NULL switch in the 10 position and then in the 1 position. If VOLTS meter indicates other than 0, adjust the VTVM-10V-1V ZERO control for a 0 reading.</p> <p>c. Place the NULL switch in the .1 position. Adjust the .1V-.01V ZERO control for a 0 reading on the VOLTS meter.</p> <p>d. Place the NULL switch in the .01 position. If the VOLTS meter indicates other than 0, adjust the .1V-.01 ZERO control for a 0 reading on the VOLTS meter.</p> <p>e. Set the VOLTS RANGE switch to the CAL position. Depress the CAL PUSH switch, and adjust the ADJ CAL control until the VOLTS meter indicates 0.</p> <p>f. Adjust the CN-16A/U for 100 volts, as read on the TS-352B/U. Depress the CAL PUSH switch and observe the VOLTS meter.</p> <p>g. Adjust the CN-16A/U for 130 volts, as read on the TS-352B/U. Depress the CAL PUSH switch and observe the VOLTS meter.</p>	<p>a. None.</p> <p>b. None</p> <p>c. None.</p> <p>d. None.</p> <p>e. None.</p> <p>f. VOLTS meter indicates 0 ± one-quarter of a division on the lower scale.</p> <p>g. VOLTS meter indicates 0 ± one-quarter of a division on the lower scale.</p>
4	AN/GSM-64: Range switch: 1000. Function switch: DC. Mode switch: AUTO. TS-352B/U: FUNCTION: AC.	VOLTS RANGE switch: 500. NULL switch: VTVM. A: 4. B: 9. C: 9. D: 9 E: 10.	Connect the AN/GSM-64 between pin 3 of V4 and the - input connector, as shown in figure 7-1. Vary the CN-16A/U between 100 and 130 volts, as read on the TS-352B/U. Observe the indicators on the AN/GSM-64.	Indicators on the AN/GSM-64 indicate between 499.99 and 500.01 volts.

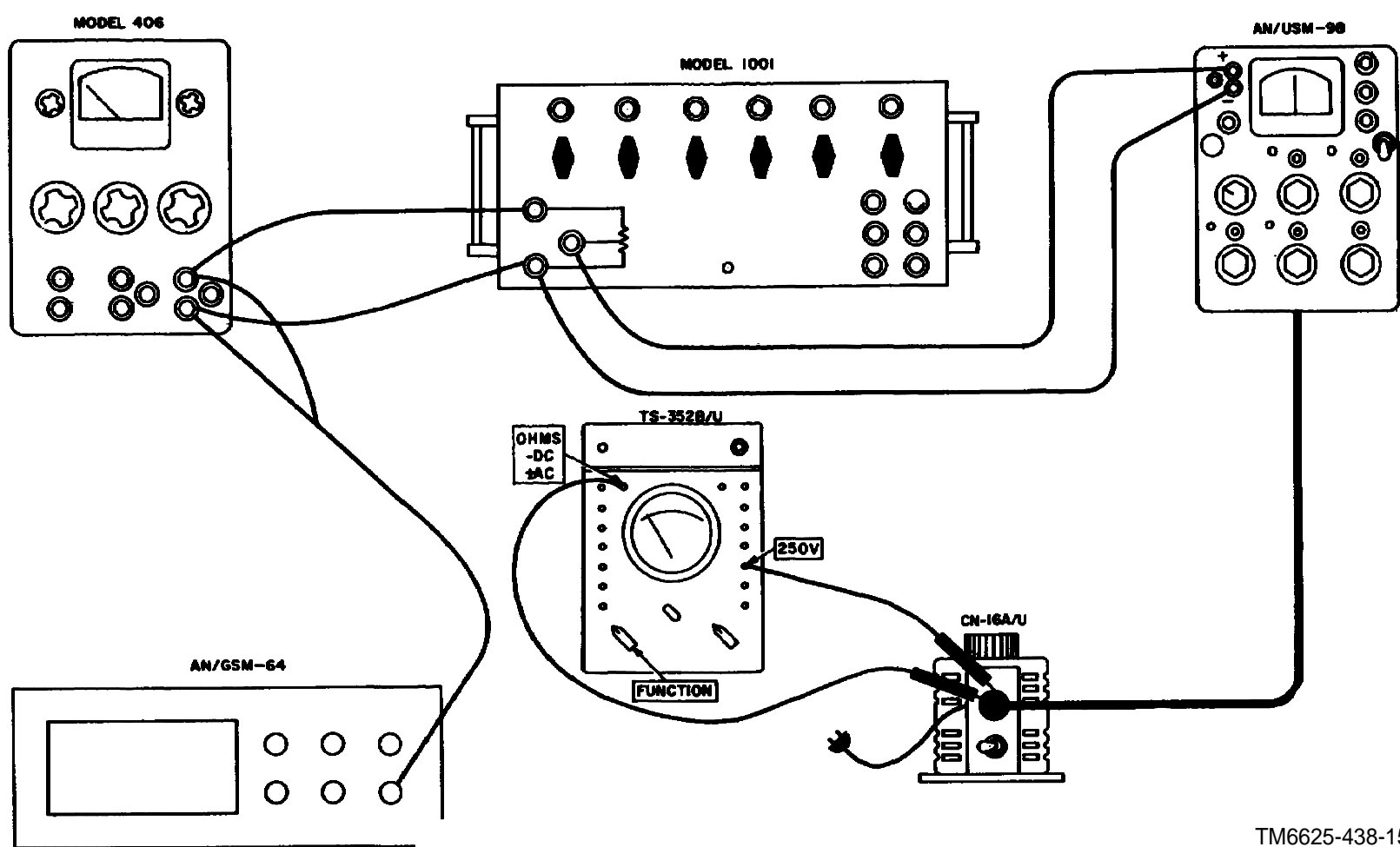

Figure 7-2. Alignment accuracy test.

7-6. Alignment Accuracy Test

a. Test Equipment Required.

- (1) Power Supply, John Fluke Model 406D, or equal.
- (2) Dc Ratio Standard, Gertsh Model 1001, or equal.
- (3) Multimeter TS-352B/U.
- (4) Voltmeter, Digital AN/GSM-64.
- (5) Variable Transformer CN-16A/U.

b. Connections. Connect the equipment as instructed below and as indicated in figure 7-2.

c. Procedure.

Caution: Be careful when making connections in the test. Voltages up to 1,000 volts are present in these circuits.

Step No.	Control settings		Test procedure	Performance standard
	Test equipment	Equipment under test		
1	<p>TS-352B/U FUNCTION: AC</p> <p>AN/GSM-64 Range switch: 1000 Function switch: DC Mode switch: AUTO MODEL 1001 999999 MODEL 406D Meter switch: E</p>	<p>NULL switch: VTVM VOLTS RANGE switch: 500. A, B, C, D, E: 0</p>	<p>a. Connect the TS-352B/U, the AN/USM-98, and the CN-16A/U as shown in figure 7-2. Adjust the CN-16A/U for a reading of 115 volts on the TS-352B/U.</p> <p>b. Adjust the VTVM-10V-1V ZERO control for a 0 reading on the VOLTS meter.</p> <p>c. Connect the model 1001, model 406D, and the AN/GSM-64 as shown in figure 7-2. Adjust the model 406D for exactly 50.00 volts on the AN/GSM-64. Observe the VOLTS meter.</p>	<p>a. None.</p> <p>b. None.</p> <p>c. VOLTS meter indicates between 480 and 520 volts.</p>
2	Same as step 1.	Same as step 1.	<p>a. Adjust the model 406D for an indication of exactly 400.00 volts on the AN/GSM-64. Observe the VOLTS meter.</p> <p>b. Adjust the model 406D for an indication of exactly 300.00 volts on the AN/GSM-64. Observe the VOLTS meter.</p> <p>c. Adjust the model 406D for an indication of exactly 200.00 volts on the AN/GSM-64. Observe the VOLTS meter.</p> <p>d. Adjust the model 406D for an indication of exactly 100.00 volts on the AN/GSM-64. Observe the VOLTS meter.</p>	<p>a. VOLTS meter indicates between +384 and 416 volts.</p> <p>b. VOLTS meter indicates between +288 and 312 volts.</p> <p>c. VOLTS meter indicates between +192 and 208 volts.</p> <p>d. VOLTS meter indicates between +96 and 104 volts.</p>
3	Same as step 1 except: Model 1001: 010000.	Same as step 1 except: VOLTS RANGE switch: 50.	Adjust the model 406D for an indication of exactly 500.00 volts on the AN/GSM-64. Observe the VOLTS meter.	VOLTS meter indicates between +48 and 52 volts.
4	Same as step 1 except: Model 1001: 001000.	Same as step 1 except: VOLTS RANGE switch: 5	Same as step 3.	VOLTS meter indicates between +4.8 and 5.2 volts.
5	Same as step 1 except: Model 1001: 000100.	Same as step 1 except: VOLTS RANGE switch: .5.	Same as step 3.	VOLTS meter indicates between +.48 and .52 volt.
6	TS-352B/U: FUNCTION: AC	VOLTS RANGE switch: .5. NULL switch: 10. A, B, C, D, E: 0	<p>a. Disconnect the leads to the AN/USM-98 input terminals. Adjust the CN-16A/U so that the TS-352B/U reads 115 volts.</p> <p>b. Adjust the VTVM-10V-1V ZERO control for a 0 reading on the VOLTS meter.</p> <p>c. Turn the NULL switch to .01. Adjust the .1-.01V ZERO control for a 0 reading on the VOLTS meter.</p> <p>d. Turn the VOLTS RANGE switch to the CAL position. Push the CAL PUSH switch in, and turn the ADJ CAL control for a 0 reading on the VOLTS meter.</p>	<p>a. None.</p> <p>b. None.</p> <p>c. None.</p> <p>d. None.</p>
7	<p>TS-352B/U: FUNCTION: AC AN/GSM-64: Range switch: 1000. Function switch: DC. Mode switch: AUTO. Model 1001: 999999 Model 406D: Meter switch: E.</p>	<p>VOLTS RANGE switch: 500. NULL switch VTVM. A: 4. B: 9. C: 9. D: 9. E: 10.</p>	<p>a. Connect the output of the model 1001 to the AN/USM-98 input terminals, as shown in figure 7-2.</p> <p>b. Adjust the model 406D for exactly 500.00 volts, as indicated on the AN/GSM-64.</p> <p>c. Turn the NULL switch to the 10, 1, .1, .01 positions. Observe the VOLTS meter at each position.</p>	<p>a. None.</p> <p>b. None.</p> <p>c. The VOLTS meter will indicate $0 \pm$ one-quarter of a small-scale division on the lower scale.</p>
8	Same as step 7 except: Caution: Before adjusting the model 1001, always place the NULL switch of the AN/USM-98 at VTVM. Model 1001: 010000.	Same as step 7 except: VOLTS RANGE switch: 50.	Turn the NULL switch to the 10, 1, .1, .01 positions. Observe the VOLTS meter at each position.	Same as step 7c.
9	Same as step 7 except: Model 1001: 001000.	Same as step 7 except: VOLTS RANGE switch 5.	Same as step 8.	Same as step 7c.
10	Same as step 7 except: Model 1001: 000100.	Same as step 7 except: VOLTS RANGE switch: .5.	Same as step 8.	Same as step 7c.

